

# cilindri compatti ISO 21287

compact cylinders ISO 21287



- Realizzati secondo la normativa ISO 21287; possibilità di interassi UNITOP  
*The cylinders are compliant to norm ISO 21287; possibility to have fixing dimensions compliant to norm UNITOP*
- Grande affidabilità e lunga durata  
*High reliability and long life time*
- Versione magnetica standard  
*Standard magnetic version*
- Esecuzioni e corse speciali a richiesta  
*Special versions and strokes on request*



## Materiali

Camicia: alluminio

Stelo: C45 cromato o INOX AISI 304

Testate: alluminio

Pistone: alluminio

Guarnizioni pistone: NBR o VITON

Guarnizione stelo: poliuretano o VITON

Magnete: plastroferrite (non adatto per temperature oltre +60°C)

## Materials

Barrel: aluminium

Piston-rod: C45 (chromium plated) or stainless steel

End-cups: aluminium

Piston: aluminium

Piston sealings: NBR or VITON

Piston-rod sealing: polyurethane or VITON

Magnet: magnetic iron compound (not suitable for temperatures over +60°C)

Pressione di esercizio <i>Working pressure</i>	max 10 bar max 1 MPa
Temperatura di esercizio <i>Temperature range</i>	standard (poliuretano/NBR): max +60°C VITON: max +110°C
Alesaggi <i>Bores</i>	25; 32; 40; 50; 63; 80; 100 mm
Tipo di costruzione <i>Construction type</i>	Profilo quadro con cava a T su tre lati <i>Square aluminium profile with T-slot on three sides</i>
Corse <i>Strokes</i>	5 ... 200 mm
Fluido <i>Fluid</i>	Aria filtrata 50µ con o senza lubrificazione <i>50µ filtered, lubricated or non lubricated air</i>



## chiave di codifica

key to codes

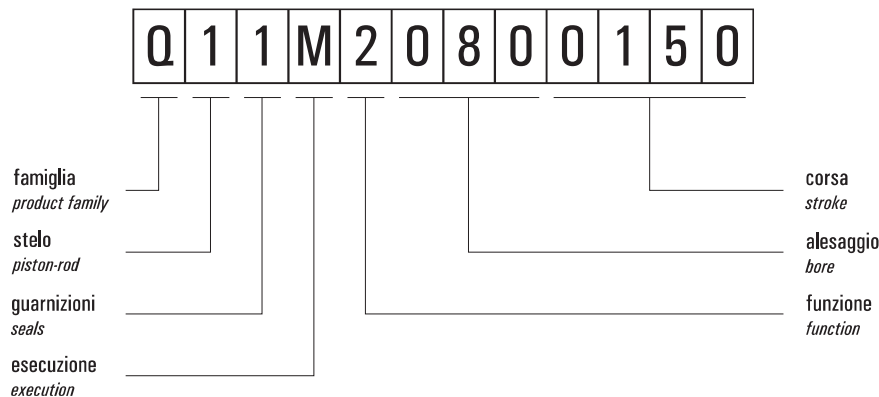

### Famiglia [product family]

- Q** cilindri compatti interasse ISO 21287  
*[compact cylinders with fixing distances ISO 21287]*
- U** cilindri compatti interasse UNITOP  
*[compact cylinders with fixing distances UNITOP]*

### Stelo [piston-rod]

- 1** C45 cromato - filetto stelo femmina  
*[C45 chromium plated - female rod thread]*
- 2** INOX - filetto stelo femmina  
*[stainless steel - female rod thread]*
- 3** C45 cromato - filetto stelo maschio  
*[C45 chromium plated - male rod thread]*
- 4** INOX - filetto stelo maschio  
*[stainless steel - male rod thread]*

### Guarnizioni [seals]

- 1** poliuretano [polyurethane]
- 2** tutte le guarnizioni in VITON [all seals in VITON]  
Attenzione: con questo tipo di guarnizioni per applicazioni ad alta temperatura, il pistone è non magnetico  
*[Attention: with this type of seals for high temperature applications, the piston is non-magnetic]*
- 3** guarnizioni dello stelo in VITON [rod seals in VITON]

### Esecuzione [execution]

- M** magnetico [magnetic]
- S** non magnetico [non-magnetic]
- D** magnetico contrapposto [magnetic opposite]
- F** magnetico, tandem in spinta stelo comune  
*[magnetic tandem cylinder, one piston rod]*
- H** magnetico, tandem in spinta steli indipendenti a due posizioni  
*[magnetic tandem cylinder, independent piston rods, two positions]*
- P** magnetico, tandem a tripla spinta stelo comune  
*[magnetic tandem cylinder, one piston rod, triple pushing]*
- L** magnetico antirotazione [magnetic anti-rotation]
- Q** magnetico basso attrito [magnetic low friction]
- R** magnetico, tandem in spinta steli indipendenti a tre posizioni  
*[magnetic tandem cylinder, independent piston rods, three positions]*

### Funzione [function]

- 1** semplice effetto non ammortizzato molla anteriore  
*[single acting front spring without pneumatic cushioning]*
- 2** doppio effetto non ammortizzato  
*[double acting without pneumatic cushioning]*
- 3** semplice effetto non ammortizzato molla posteriore  
*[single acting back spring without pneumatic cushioning]*
- 4** doppio effetto non ammortizzato stelo passante  
*[double acting without pneumatic cushioning, with passing-through rod]*
- 5** semplice effetto non ammortizzato stelo passante  
*[single acting without pneumatic cushioning, with passing-through rod]*
- 8** doppio effetto non ammortizzato stelo passante forato  
*[double acting without pneum. cushioning, perforated passing-through rod]*

# cilindri compatti ISO 21287

compact cylinders ISO 21287



## versioni disponibili

available versions

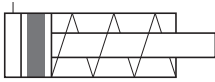
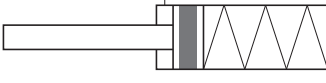
<b>semplice effetto molla anteriore</b> <i>single acting front spring</i> <b>magnetico</b> <i>magnetic</i> <b>non ammortizzato</b> <i>without pneumatic cushioning</i>	alesaggio		25	32	40	50	63	80	100	<b>OPZIONI</b> <i>options</i>  Lo standard è evidenziato in grigio The standard is marked with grey background					
	corsa	bore									stroke				
	5		X	X	X	X	X	X	X		<b>materiale stelo [piston-rod material]</b> C45 cromato <i>C45 chromium plated</i>	<b>INOX</b> <i>stainless steel</i>			
	10		X	X	X	X	X	X	X				<b>materiale guarnizioni [seals material]</b>  poliuret.    tutte in VITON <i>all seals in VITON</i>	guarnizioni stelo in VITON <i>rod seals in VITON</i>	
	25		X	X	X	X	X	X	X			<b>filetto stelo [rod thread]</b> filetto stelo femmina <i>female rod thread</i>			filetto stelo maschio <i>male rod thread</i>
	30				X	X	X	X	X						
	40														
	50														
	75														
	80														
	100														
	125														
	150														
	160														
	200														
	<b>semplice eff. molla posteriore</b> <i>single acting back spring</i> <b>magnetico</b> <i>magnetic</i> <b>non ammortizzato</b> <i>without pneumatic cushioning</i>	alesaggio		25	32	40	50	63	80	100		<b>OPZIONI</b> <i>options</i>  Lo standard è evidenziato in grigio The standard is marked with grey background			
corsa		bore	stroke												
		5		X	X	X	X	X	X	X	<b>materiale stelo [piston-rod material]</b> C45 cromato <i>C45 chromium plated</i>		<b>INOX</b> <i>stainless steel</i>		
		10		X	X	X	X	X	X	X				<b>materiale guarnizioni [seals material]</b>  poliuret.    tutte in VITON <i>all seals in VITON</i>	guarnizioni stelo in VITON <i>rod seals in VITON</i>
		25		X	X	X	X	X	X	X			<b>filetto stelo [rod thread]</b> filetto stelo femmina <i>female rod thread</i>		
		30				X	X	X	X	X					
		40													
		50													
		75													
		80													
		100													
		125													
		150													
		160													
	200														

## versioni disponibili

available versions

<b>doppio effetto</b> <i>double acting</i> <b>magnetico</b> <i>magnetic</i> <b>non ammortizzato</b> <i>without pneumatic cushioning</i>	alesaggio		25	32	40	50	63	80	100	<b>OPZIONI</b> <i>options</i>  Lo standard è evidenziato in grigio <i>The standard is marked with grey background</i>		
	corsa	bore									stroke	
	5		X	X	X	X	X	X	X		<b>materiale stelo [piston-rod material]</b>  C45 cromato <i>C45 chromium plated</i>	INOX <i>stainless steel</i>
	10		X	X	X	X	X	X	X			
	25		X	X	X	X	X	X	X			
	30		X	X	X	X	X	X	X			
	40		X	X	X	X	X	X	X			
	50		X	X	X	X	X	X	X			
	75		X	X	X	X	X	X	X			
	80		X	X	X	X	X	X	X			
	100		X	X	X	X	X	X	X			
	125		X	X	X	X	X	X	X			
	150		X	X	X	X	X	X	X			
	160		X	X	X	X	X	X	X			
	200		X	X	X	X	X	X	X			
	<b>doppio effetto</b> <i>double acting</i> <b>magnetico</b> <i>magnetic</i> <b>non ammortizzato</b> <i>without pneumatic cushioning</i> <b>stelo passante</b> <i>passing-through rod</i>	5		X	X	X	X	X	X	X		
10			X	X	X	X	X	X	X			
25			X	X	X	X	X	X	X			
30			X	X	X	X	X	X	X			
40			X	X	X	X	X	X	X			
50			X	X	X	X	X	X	X			
75			X	X	X	X	X	X	X			
80			X	X	X	X	X	X	X			
100			X	X	X	X	X	X	X			
125			X	X	X	X	X	X	X			
150			X	X	X	X	X	X	X			
160			X	X	X	X	X	X	X			
200			X	X	X	X	X	X	X			

6

# cilindri compatti ISO 21287

compact cylinders ISO 21287

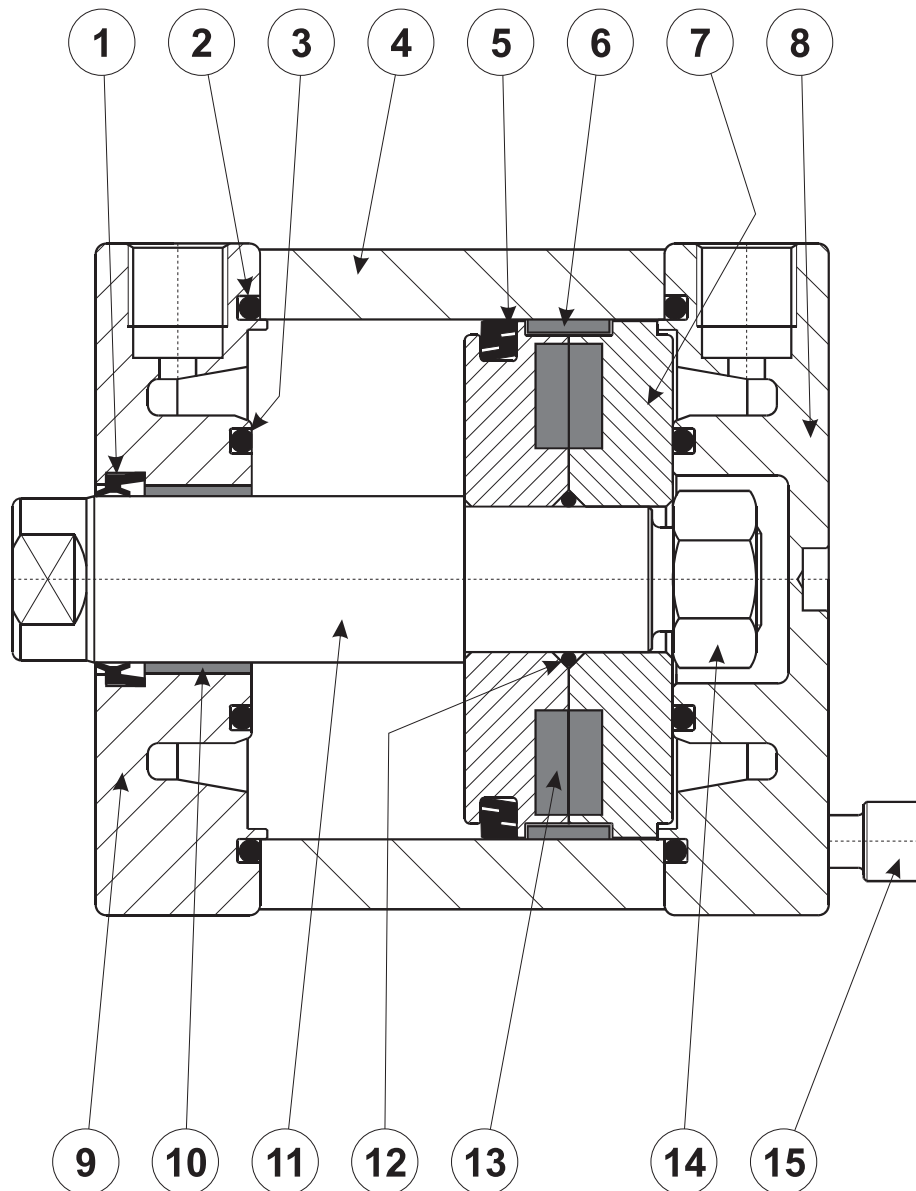

1. Guarnizione stelo: poliuretano o VITON
2. O-Ring per tenuta testata: NBR o VITON
3. O-Ring paracolpi: NBR o VITON
4. Camicia: alluminio profilato, calibrato e anodizzato
5. Guarnizione tenuta pistone: NBR o VITON
6. Anello guida per pistone: PTFE
7. Pistone: alluminio
8. Testata posteriore: alluminio anodizzato
9. Testata anteriore: alluminio anodizzato
10. Boccola guida stelo: materiale autolubrificante
11. Stelo: acciaio C45 cromato o INOX AISI 304
12. O-Ring per tenuta pistone: NBR o VITON
13. Magnete:  $\varnothing 25$  neodimio;  $\varnothing 32-100$  plastoferrite
14. Dado per bloccaggio stelo: acciaio zincato
15. Vite autofilettante per fissaggio testata: acciaio zincato



## KIT GUARNIZIONI DI RICAMBIO

seals kit

<b>MAGNETICO, guarnizioni standard</b>					
<b>normale</b>			<b>stelo passante [passing-through rod]</b>		
per alesaggio for bore	sigla part number	codice code	per alesaggio for bore	sigla part number	codice code
25	<b>GQ025</b>	39.102.2	25	<b>GQ025P</b>	39.112.2
32	<b>GQ032</b>	39.103.2	32	<b>GQ032P</b>	39.113.2
40	<b>GQ040</b>	39.104.2	40	<b>GQ040P</b>	39.114.2
50	<b>GQ050</b>	39.105.2	50	<b>GQ050P</b>	39.115.2
63	<b>GQ063</b>	39.106.2	63	<b>GQ063P</b>	39.116.2
80	<b>GQ080</b>	39.107.2	80	<b>GQ080P</b>	39.117.2
100	<b>GQ100</b>	39.108.2	100	<b>GQ100P</b>	39.118.2
<b>MAGNETICO, guarnizioni VITON</b>					
<b>normale</b>			<b>stelo passante [passing-through rod]</b>		
per alesaggio for bore	sigla part number	codice code	per alesaggio for bore	sigla part number	codice code
25	<b>GQ025V</b>	39.122.2	25	<b>GQ025PV</b>	39.132.2
32	<b>GQ032V</b>	39.123.2	32	<b>GQ032PV</b>	39.133.2
40	<b>GQ040V</b>	39.124.2	40	<b>GQ040PV</b>	39.134.2
50	<b>GQ050V</b>	39.125.2	50	<b>GQ050PV</b>	39.135.2
63	<b>GQ063V</b>	39.126.2	63	<b>GQ063PV</b>	39.136.2
80	<b>GQ080V</b>	39.127.2	80	<b>GQ080PV</b>	39.137.2
100	<b>GQ100V</b>	39.128.2	100	<b>GQ100PV</b>	39.138.2

6

# cilindri compatti ISO 21287

compact cylinders ISO 21287



## VERSIONE MAGNETICA, FILETTO STELO FEMMINA, ALESAGGIO 25 mm

magnetic version, female rod thread, bore 25 mm

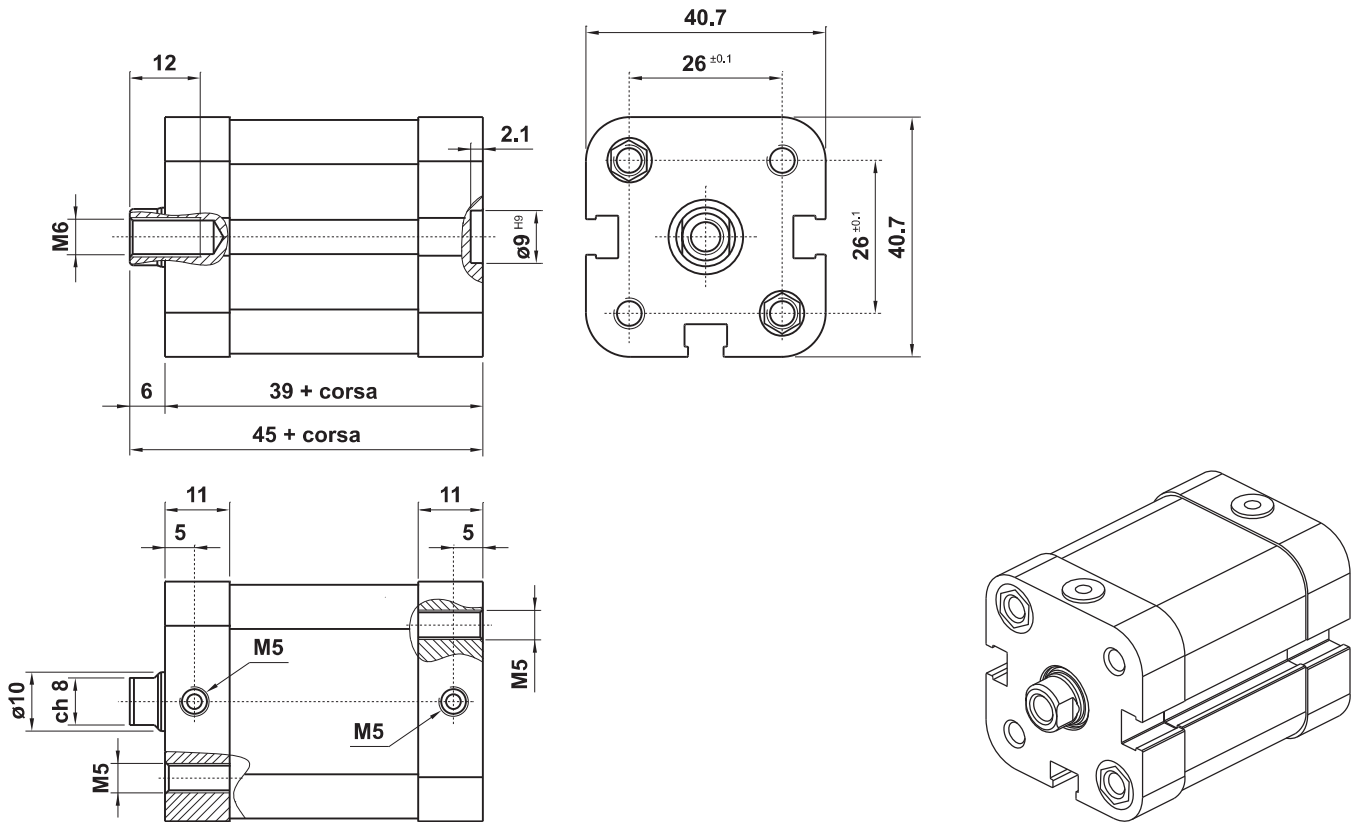

6

## VERSIONE MAGNETICA, FIL. STELO FEMMINA, STELO PASS., ALES. 25 mm

magnetic version, female rod thread, passing-through rod, bore 25 mm

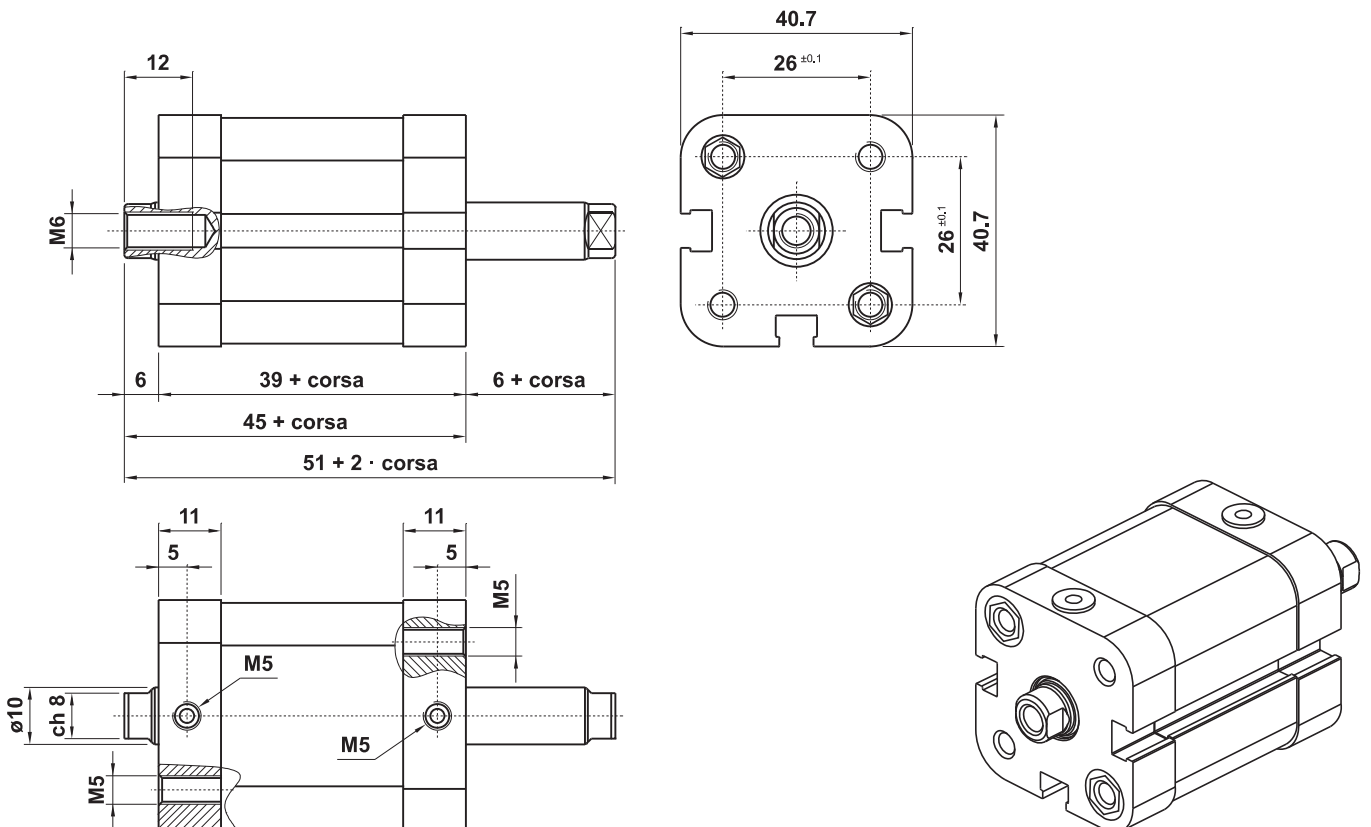

# cilindri compatti ISO 21287

compact cylinders ISO 21287



## VERSIONE MAGNETICA, FILETTO STELO MASCHIO, ALESAGGIO 25 mm

magnetic version, male rod thread, bore 25 mm

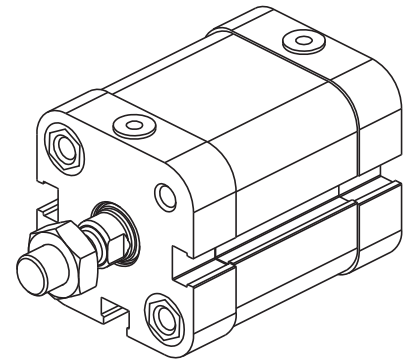
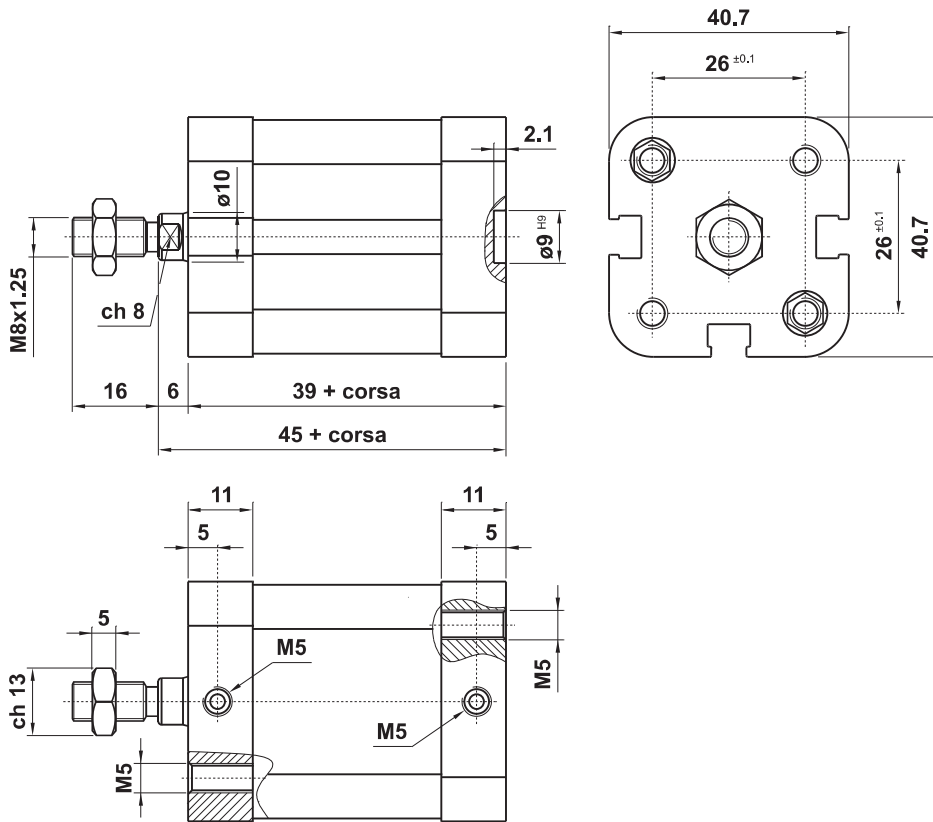

## VERSIONE MAGNETICA, FIL. STELO MASCHIO, STELO PASS., ALES. 25 mm

magnetic version, male rod thread, passing-through rod, bore 25 mm

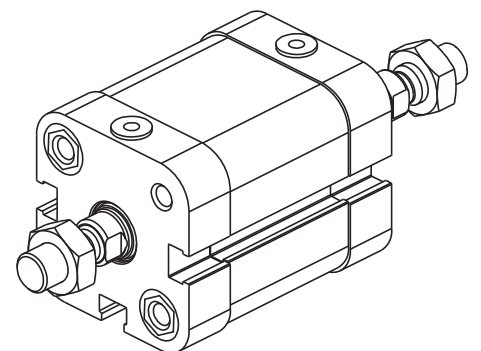
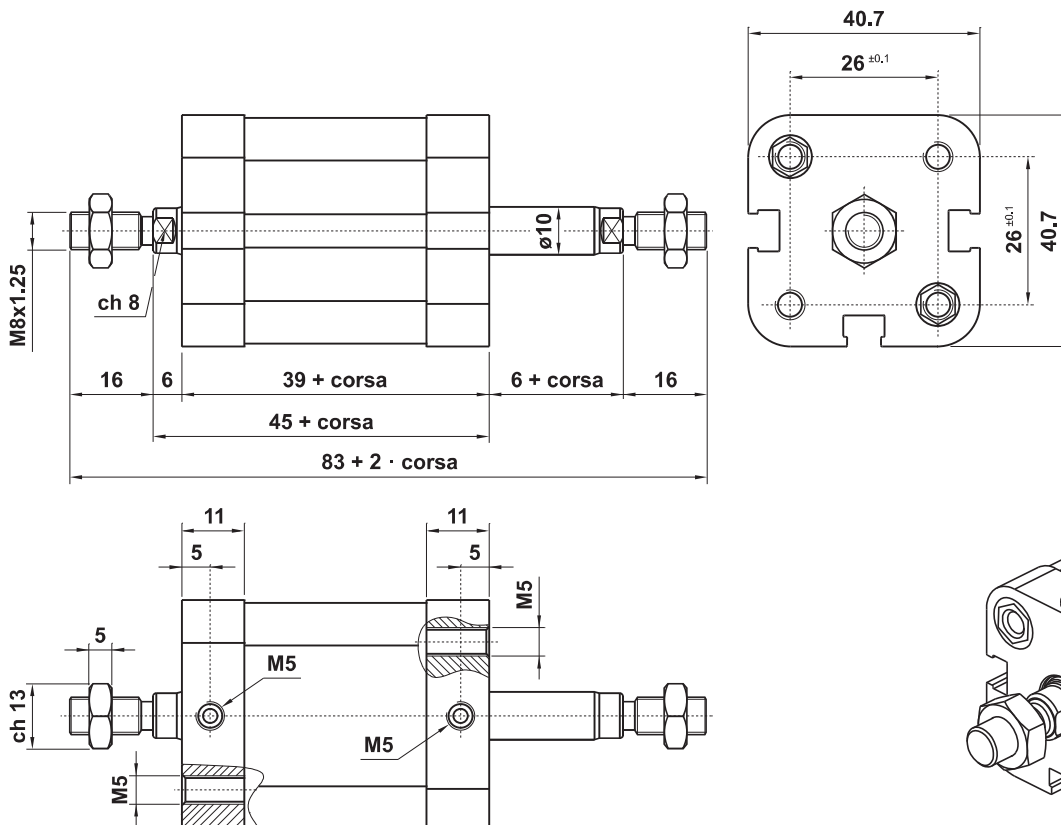



# cilindri compatti ISO 21287

compact cylinders ISO 21287



## VERSIONE MAGNETICA, ANTIROTAZIONE, ALESAGGIO 25 mm

magnetic version, anti-rotation, bore 25 mm

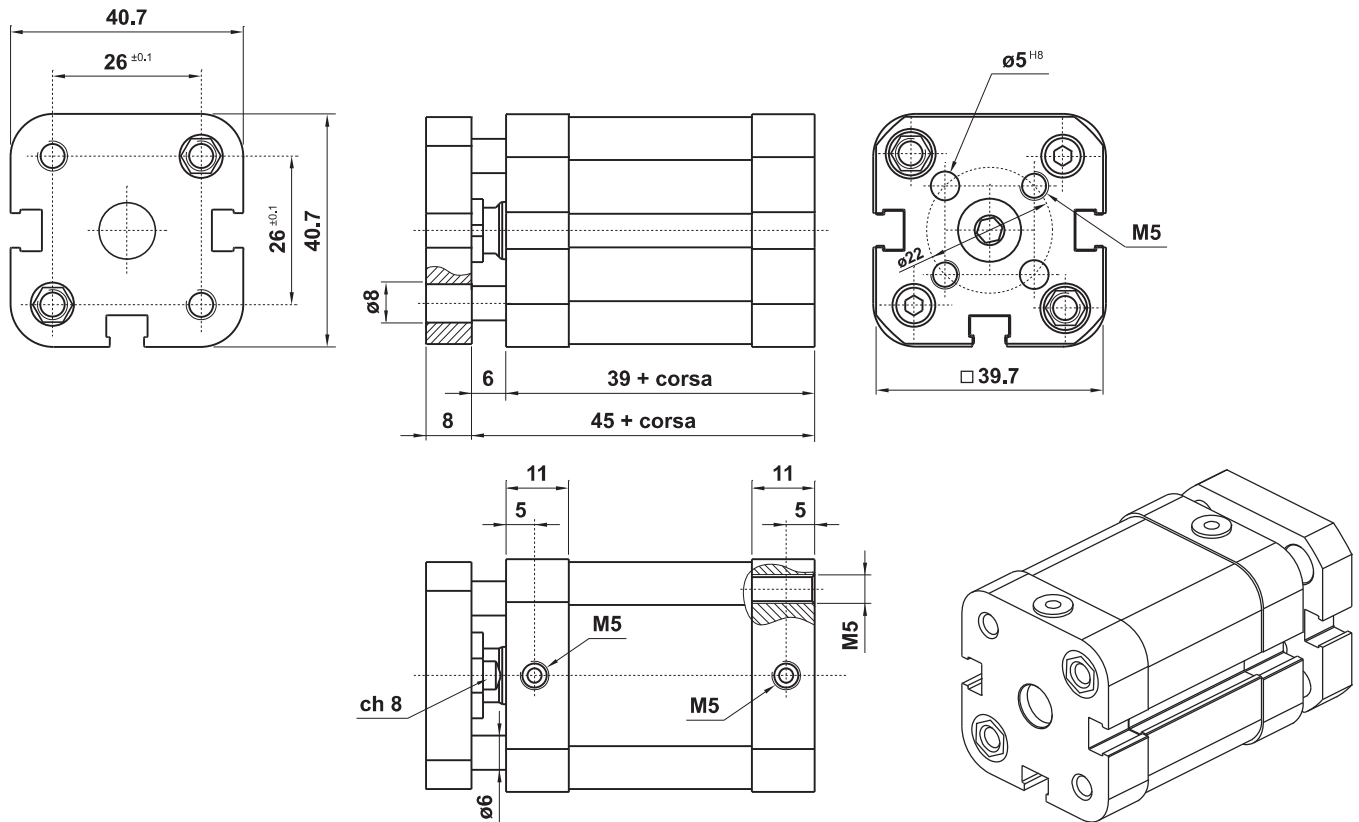

## VERSIONE MAGNETICA, ANTIROTAZIONE, STELO PASS., ALESAGGIO 25 mm

magnetic version, anti-rotation, passing-through rod, bore 25 mm

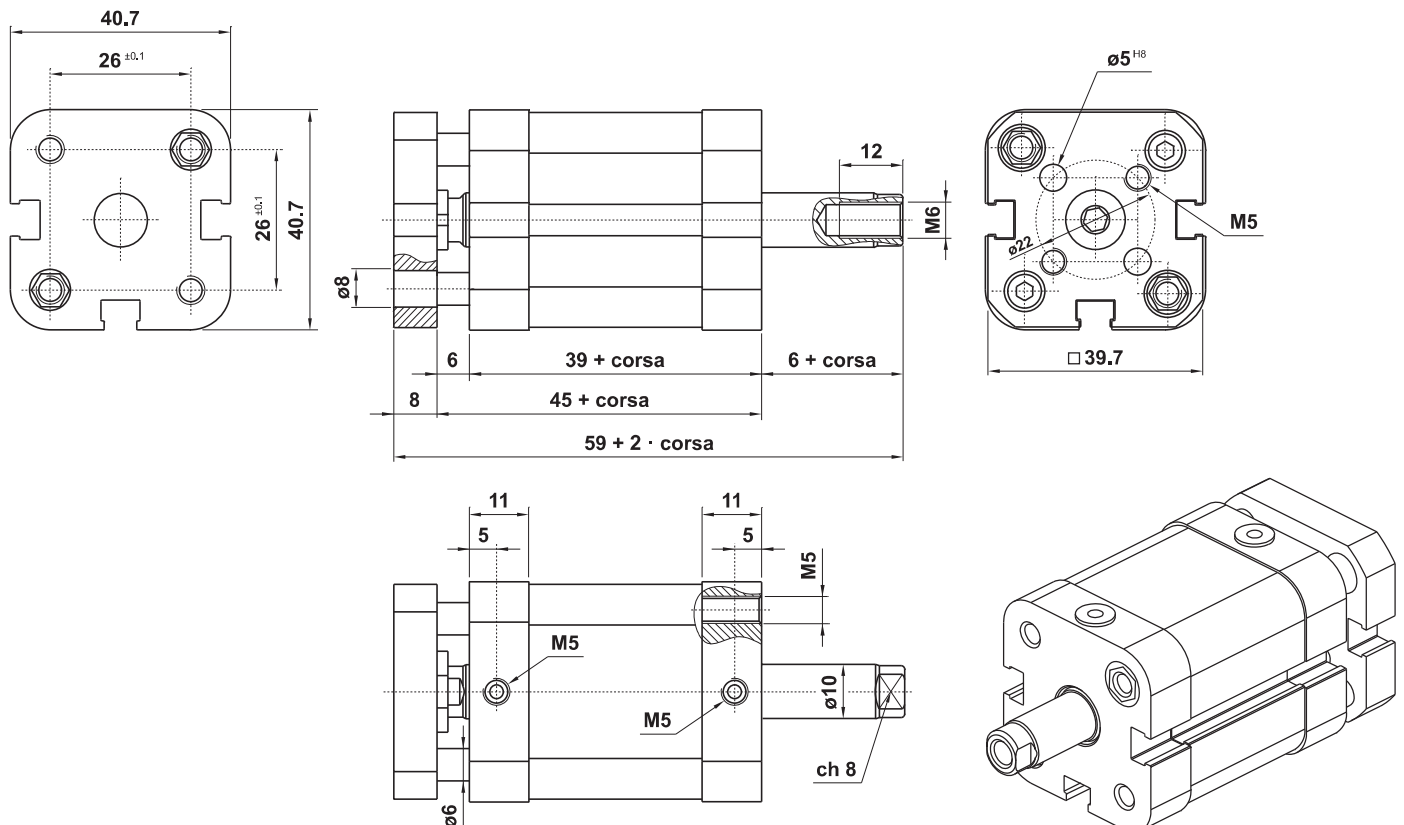



## VERSIONE MAGNETICA, FILETTO STELO FEMMINA

magnetic version, female rod thread

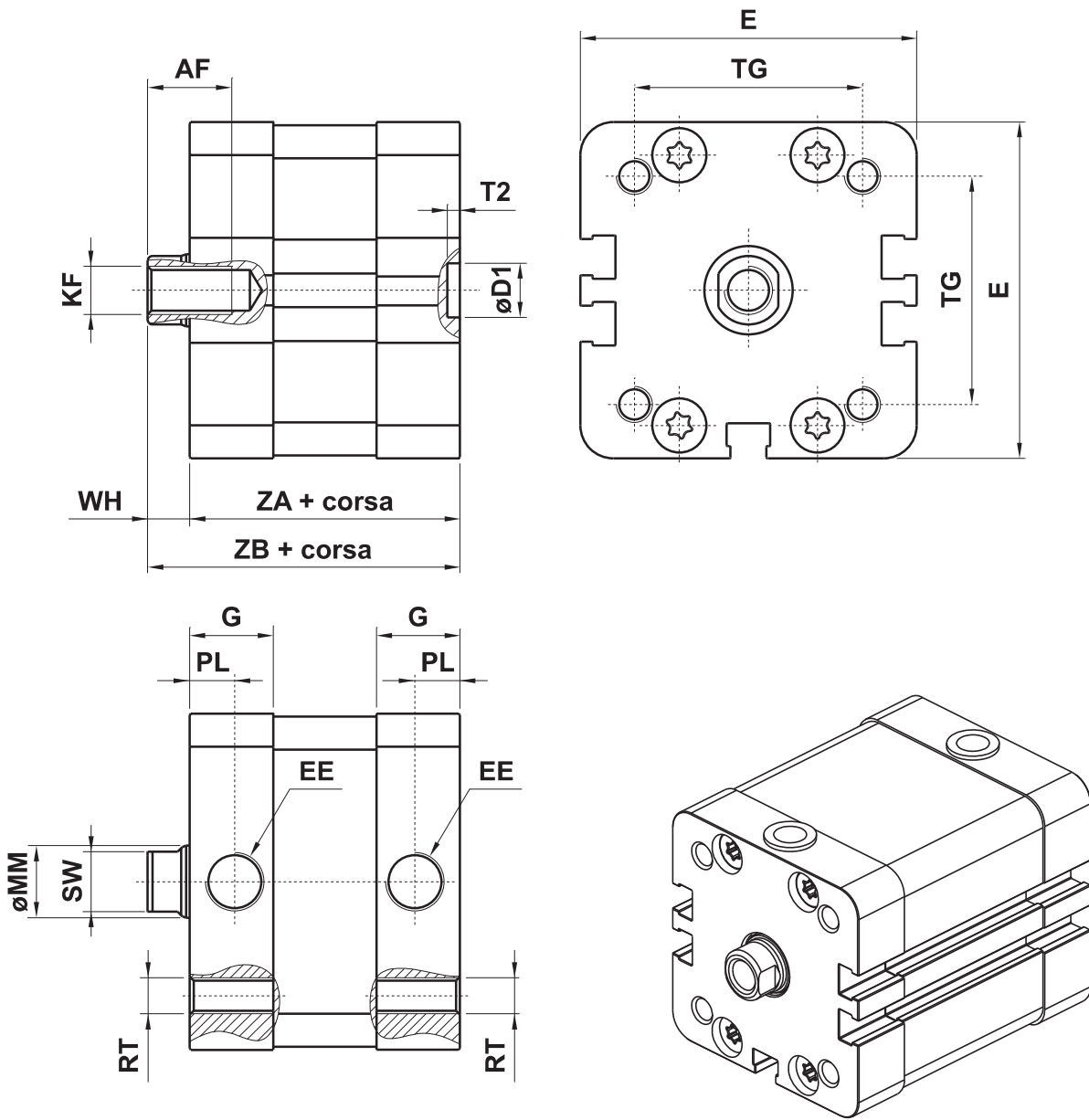

### ISO 21287

ø	AF	øD1 <sub>H9</sub>	E	EE	G	KF	øMM	PL	RT	SW	TG ±0.1		T2	WH	ZA	ZB
											ISO	UNITOP				
32	14	9	49	G1/8"	13.9	M8	12	7.5	M6	ch 10	32.5	32.5	2.1	7	44	51
40	14	9	56	G1/8"	14.7	M8	12	7.5	M6	ch 10	38	42	2.1	7	45	52
50	16	12	69	G1/8"	14.3	M10	16	7.5	M8	ch 13	46.5	50	2.6	8	45	53
63	16	12	79	G1/8"	15.8	M10	16	7.5	M8	ch 13	56.5	62	2.6	8	49	57
80	20	12	95	G1/8"	16.4	M12	20	7.5	M10	ch 17	72	82	2.6	10	54	64
100	24	12	115.5	G1/8"	17.5	M12	25	7.5	M10	ch 22	89	103	2.6	10	67	77

# cilindri compatti ISO 21287

compact cylinders ISO 21287



## VERSIONE MAGNETICA, FILETTO STELO MASCHIO

magnetic version, male rod thread

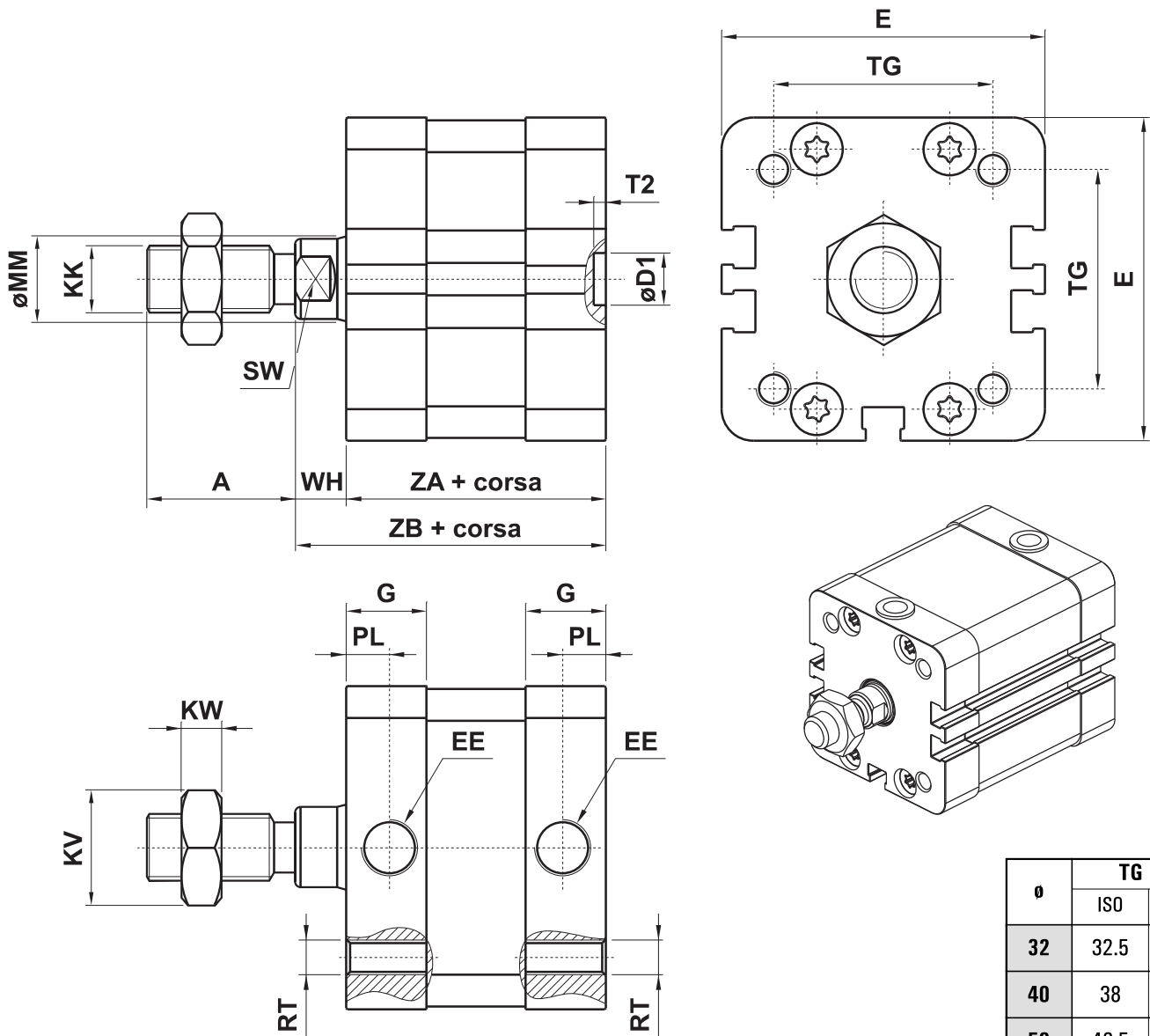

ø	TG ±0.1	
	ISO	UNITOP
32	32.5	32.5
40	38	42
50	46.5	50
63	56.5	62
80	72	82
100	89	103

### ISO 21287

ø	A	øD1 H9	E	EE	G	KK	KV	KW	øMM	PL	RT	SW	T2	WH	ZA	ZB
32	19	9	49	G1/8"	13.9	M10x1.25	ch 17	6	12	7.5	M6	ch 10	2.1	7	44	51
40	19	9	56	G1/8"	14.7	M10x1.25	ch 17	6	12	7.5	M6	ch 10	2.1	7	45	52
50	22	12	69	G1/8"	14.3	M12x1.25	ch 19	7	16	7.5	M8	ch 13	2.6	8	45	53
63	22	12	79	G1/8"	15.8	M12x1.25	ch 19	7	16	7.5	M8	ch 13	2.6	8	49	57
80	28	12	95	G1/8"	16.4	M16x1.5	ch 24	8	20	7.5	M10	ch 17	2.6	10	54	64
100	28	12	115.5	G1/8"	17.5	M16x1.5	ch 24	8	25	7.5	M10	ch 22	2.6	10	67	77

# cilindri compatti ISO 21287

compact cylinders ISO 21287



## VERSIONE MAGNETICA, FILETTO STELO FEMMINA, STELO PASSANTE

magnetic version, female rod thread, passing-through rod

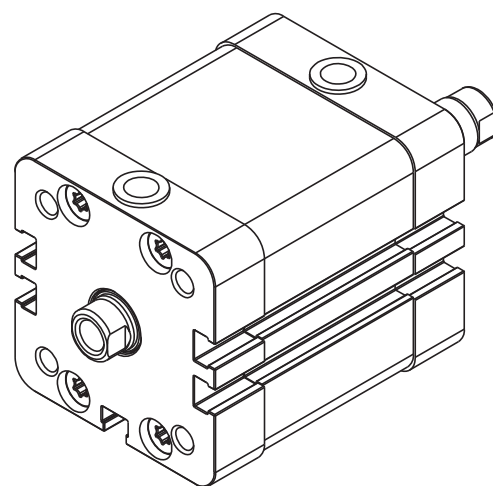
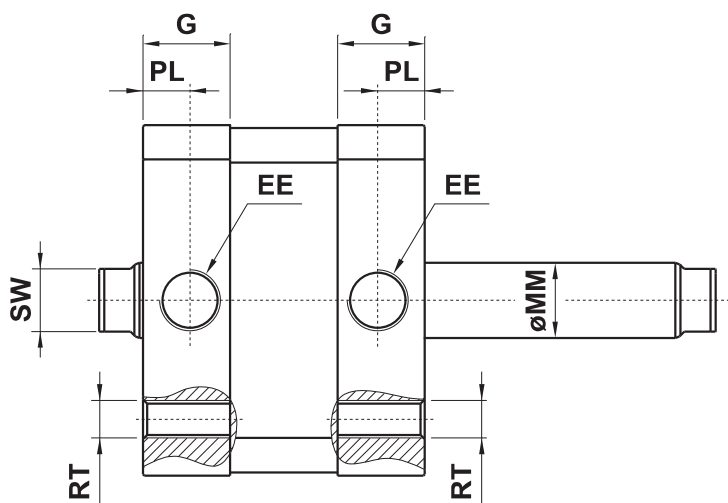
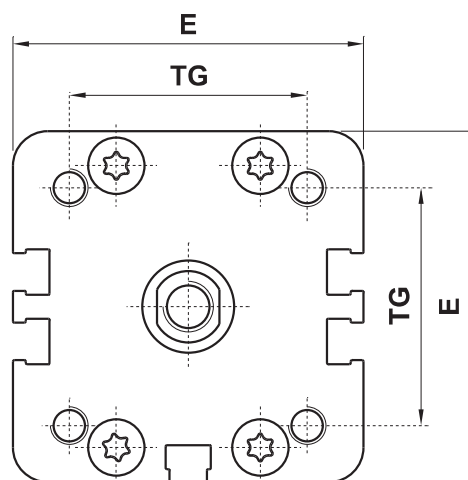
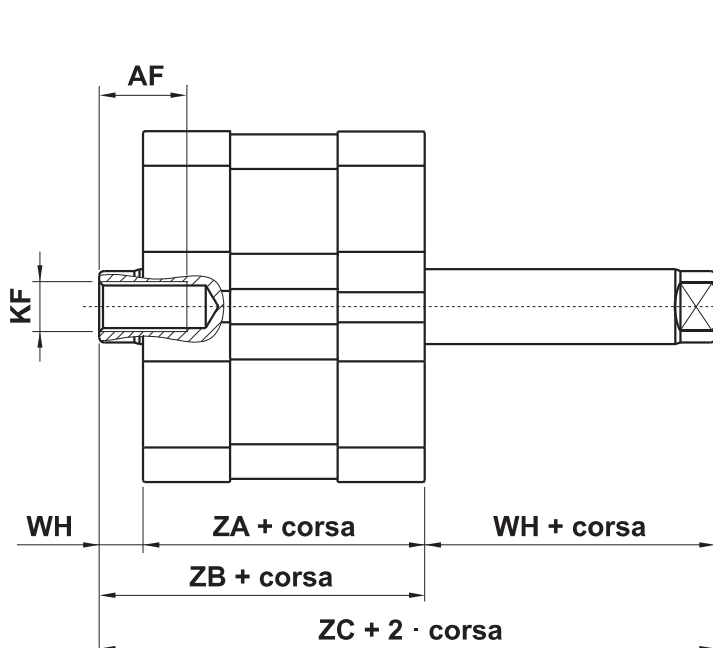

### ISO 21287

ø	AF	E	EE	G	KF	øMM	PL	RT	SW	TG ±0.1		WH	ZA	ZB	ZC
										ISO	UNITOP				
32	14	49	G1/8"	13.9	M8	12	7.5	M6	ch 10	32.5	32.5	7	44	51	58
40	14	56	G1/8"	14.7	M8	12	7.5	M6	ch 10	38	42	7	45	52	59
50	16	69	G1/8"	14.3	M10	16	7.5	M8	ch 13	46.5	50	8	45	53	61
63	16	79	G1/8"	15.8	M10	16	7.5	M8	ch 13	56.5	62	8	49	57	65
80	20	95	G1/8"	16.4	M12	20	7.5	M10	ch 17	72	82	10	54	64	74
100	24	115.5	G1/8"	17.5	M12	25	7.5	M10	ch 22	89	103	10	67	77	87

# cilindri compatti ISO 21287

compact cylinders ISO 21287



## VERSIONE MAGNETICA, FILETTO STELO MASCHIO, STELO PASSANTE

magnetic version, male rod thread, passing-through rod

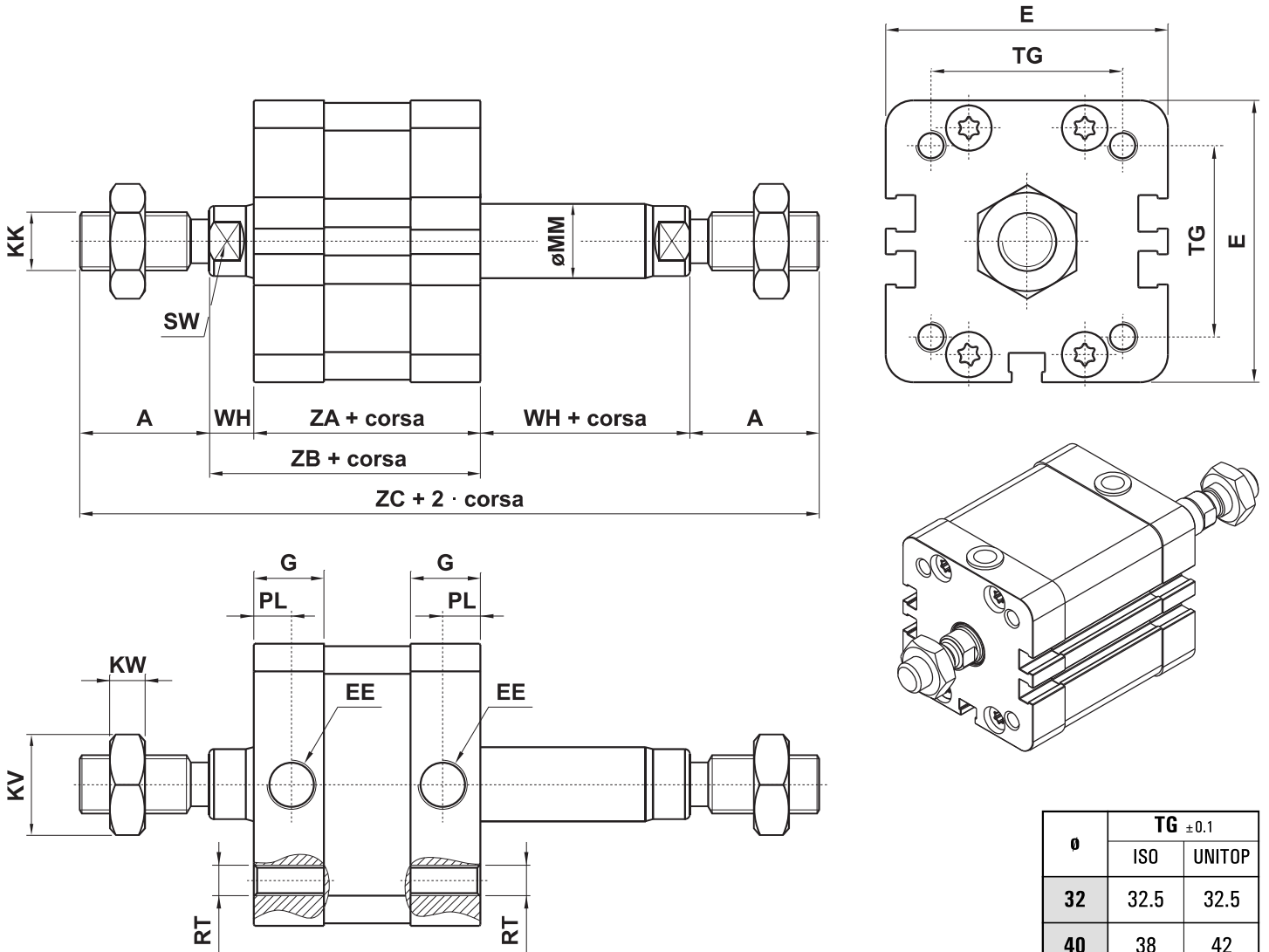

### ISO 21287

ø	TG ±0.1	
	ISO	UNITOP
32	32.5	32.5
40	38	42
50	46.5	50
63	56.5	62
80	72	82
100	89	103

ø	A	E	EE	G	KK	KV	KW	øMM	PL	RT	SW	WH	ZA	ZB	ZC
32	19	49	G1/8"	13.9	M10x1.25	ch 17	6	12	7.5	M6	ch 10	7	44	51	96
40	19	56	G1/8"	14.7	M10x1.25	ch 17	6	12	7.5	M6	ch 10	7	45	52	97
50	22	69	G1/8"	14.3	M12x1.25	ch 19	7	16	7.5	M8	ch 13	8	45	53	105
63	22	79	G1/8"	15.8	M12x1.25	ch 19	7	16	7.5	M8	ch 13	8	49	57	109
80	28	95	G1/8"	16.4	M16x1.5	ch 24	8	20	7.5	M10	ch 17	10	54	64	130
100	28	115.5	G1/8"	17.5	M16x1.5	ch 24	8	25	7.5	M10	ch 22	10	67	77	143

# cilindri compatti ISO 21287

compact cylinders ISO 21287



## VERSIONE MAGNETICA, ANTIROTAZIONE

magnetic version, anti-rotation

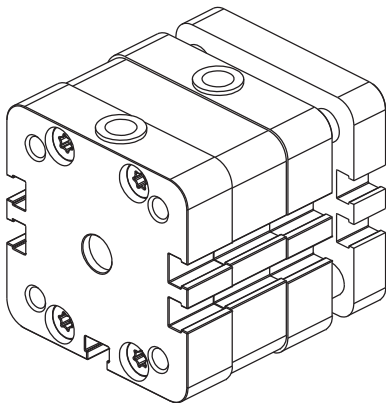
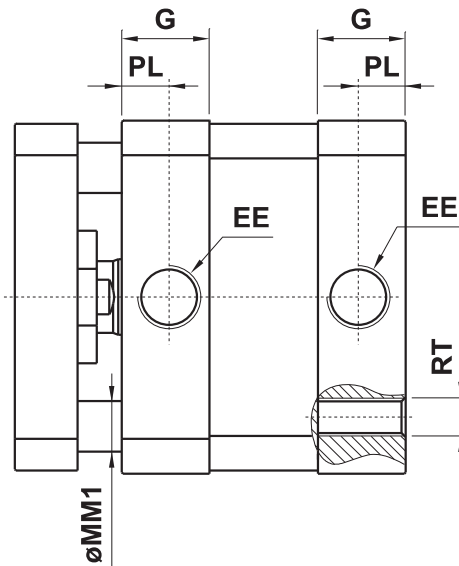
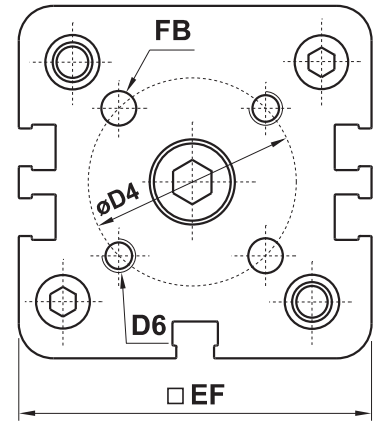
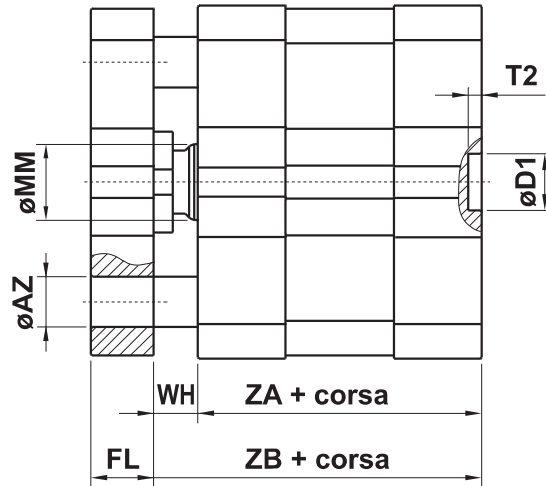
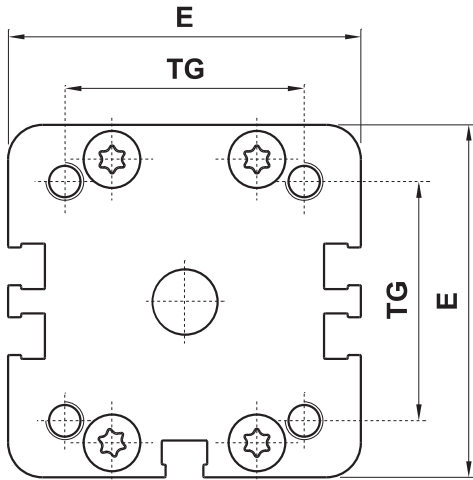

$\phi$	TG $\pm 0.1$	
	ISO	UNITOP
32	32.5	32.5
40	38	42
50	46.5	50
63	56.5	62
80	72	82
100	89	103

### ISO 21287

$\phi$	$\phi AZ$	$\phi D1_{H9}$	$\phi D4$	D6	E	EE	EF	$\phi FB_{H8}$	FL	G	KF	$\phi MM$	$\phi MM1$	PL	RT	SW	T2	WH	ZA	ZB
32	8	9	28	M5	49	G1/8"	48.2	5	10	13.9	M8	12	6	7.5	M6	ch 10	2.1	7	44	51
40	8	9	33	M5	56	G1/8"	55	5	10	14.7	M8	12	8	7.5	M6	ch 10	2.1	7	45	52
50	11	12	42	M6	69	G1/8"	68	6	12	14.3	M10	16	10	7.5	M8	ch 13	2.6	8	45	53
63	11	12	50	M6	79	G1/8"	78	6	12	15.8	M10	16	10	7.5	M8	ch 13	2.6	8	49	57
80	15	12	65	M8	95	G1/8"	94	8	14	16.4	M12	20	12	7.5	M10	ch 17	2.6	10	54	64
100	15	12	80	M10	115.5	G1/8"	114.5	10	14	17.5	M12	25	12	7.5	M10	ch 22	2.6	10	67	77

# cilindri compatti ISO 21287

compact cylinders ISO 21287



## VERSIONE MAGNETICA, ANTIROTAZIONE, STELO PASSANTE

magnetic version, anti-rotation, passing-through rod

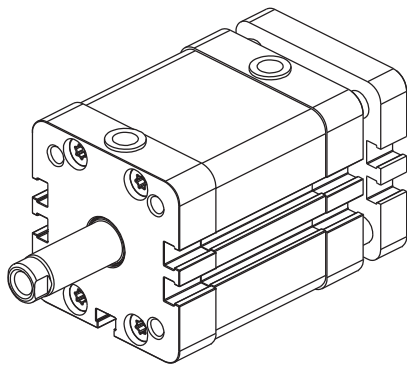
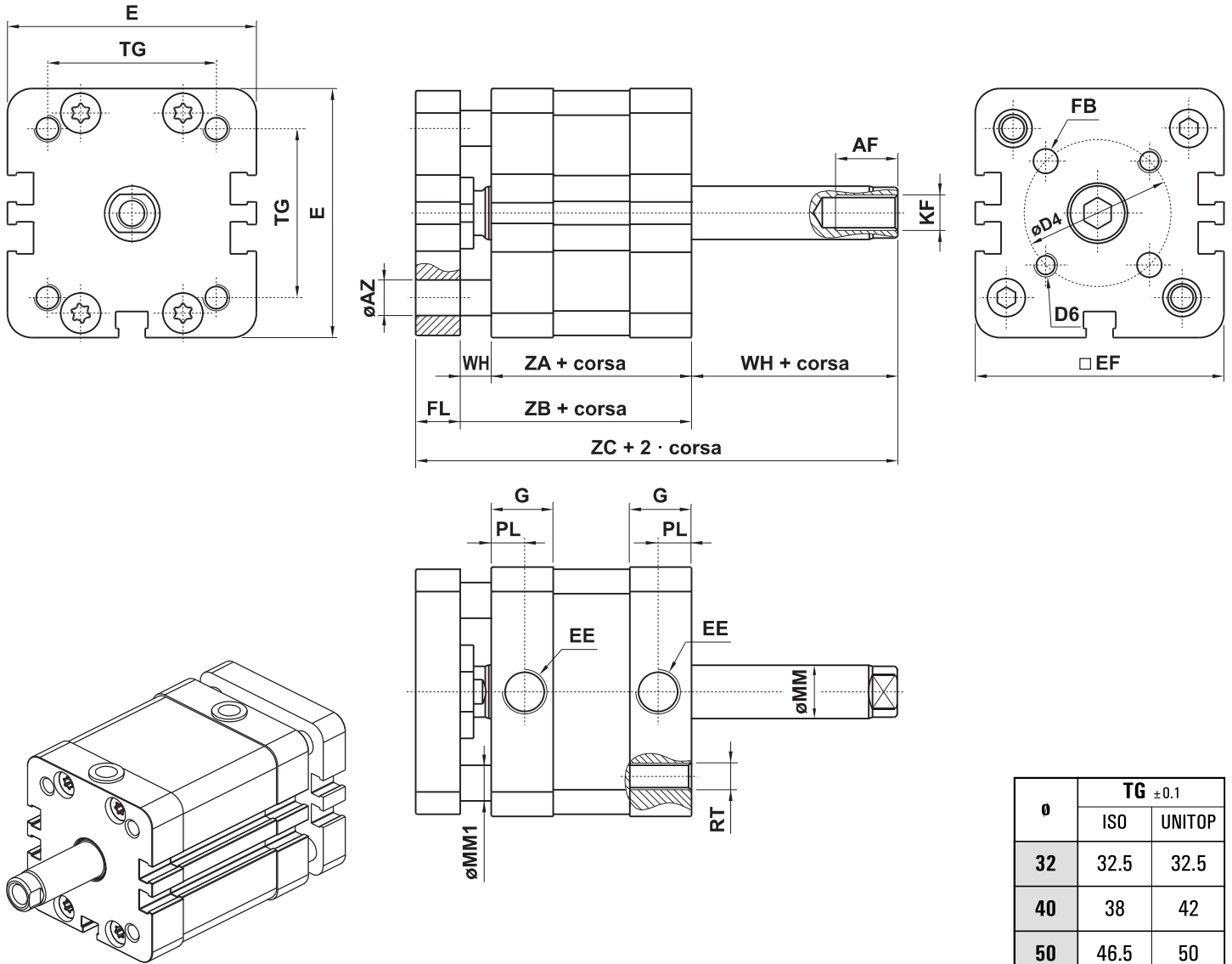

ø	TG ±0.1	
	ISO	UNITOP
32	32.5	32.5
40	38	42
50	46.5	50
63	56.5	62
80	72	82
100	89	103

### ISO 21287

ø	AF	øAZ	øD4	D6	E	EE	EF	øFB <sub>H8</sub>	FL	G	KF	øMM	øMM1	PL	RT	SW	WH	ZA	ZB	ZC
32	14	8	28	M5	49	G1/8"	48.2	5	10	13.9	M8	12	6	7.5	M6	ch 10	7	44	51	68
40	14	8	33	M5	56	G1/8"	55	5	10	14.7	M8	12	8	7.5	M6	ch 10	7	45	52	69
50	16	11	42	M6	69	G1/8"	68	6	12	14.3	M10	16	10	7.5	M8	ch 13	8	45	53	73
63	16	11	50	M6	79	G1/8"	78	6	12	15.8	M10	16	10	7.5	M8	ch 13	8	49	57	77
80	20	15	65	M8	95	G1/8"	94	8	14	16.4	M12	20	12	7.5	M10	ch 17	10	54	64	88
100	24	15	80	M10	115.5	G1/8"	114.5	10	14	17.5	M12	25	12	7.5	M10	ch 22	10	67	77	101

# cilindri compatti ISO 21287

compact cylinders ISO 21287



## DOBPIO EFFETTO, STELO PASSANTE FORATO, FILETTO STELO FEMMINA

double acting, perforated passing-through rod, female rod thread

alesaggio bore	A	B	øD	corsa massima maximum stroke
25	M5	10	2.5	235
32	M5	10	3.5	290
40	M5	10	3.5	290
50	G1/8"	10	5	355
63	G1/8"	10	5	460
80	G1/4"	11	8	450
100	G1/4"	11	10	500

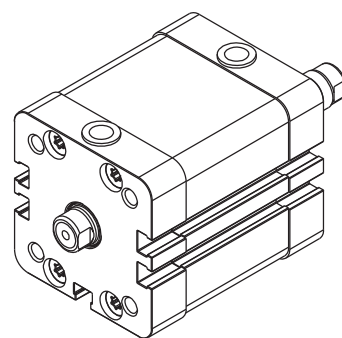
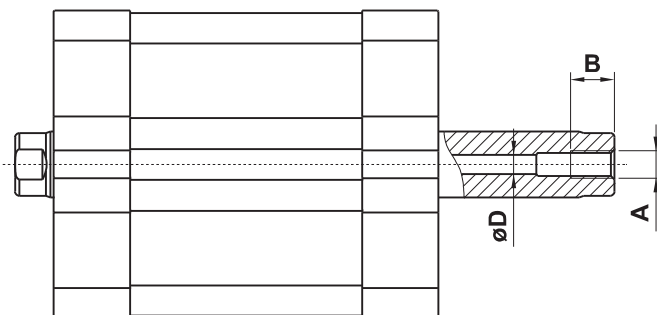

## DOBPIO EFFETTO, STELO PASSANTE FORATO, FILETTO STELO MASCHIO

double acting, perforated passing-through rod, male rod thread

alesaggio bore	A	B	øD	corsa massima maximum stroke
25	M5	10	2.5	220
32	M5	10	3.5	275
40	M5	10	3.5	275
50	G1/8"	10	5	330
63	G1/8"	10	5	430
80	G1/4"	11	8	425
100	G1/4"	11	10	470

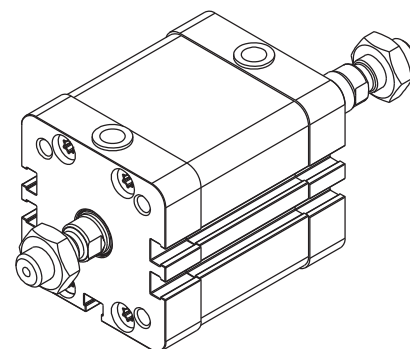
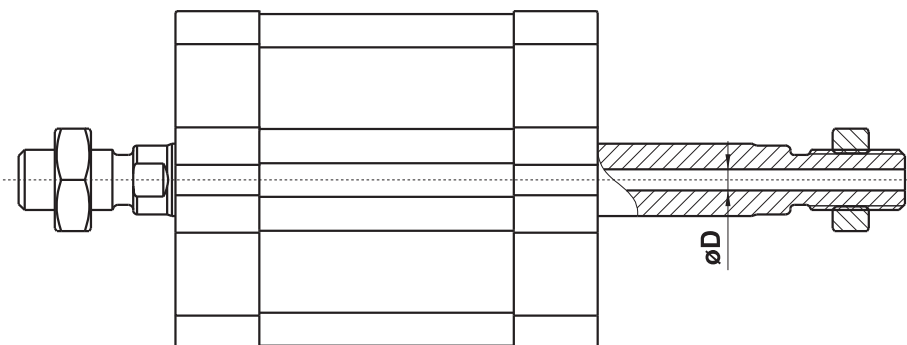



## TANDEM IN SPINTA STELI INDIPENDENTI DUE POSIZIONI

tandem cylinder, independent piston rods, two positions

Esempio di codifica

Example of order code

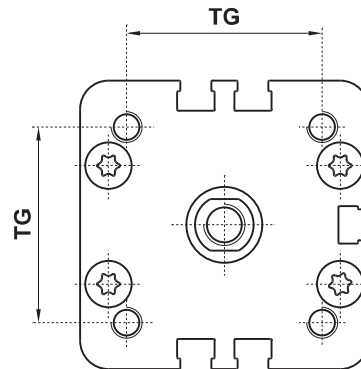
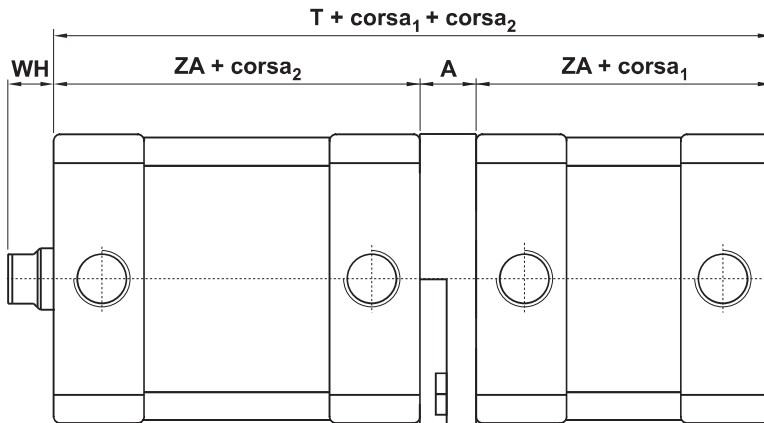

Q11H20320080/0100  
corsa<sub>1</sub> corsa<sub>2</sub>

U11H20320080/0100  
corsa<sub>1</sub> corsa<sub>2</sub>

## TANDEM IN SPINTA STELO COMUNE

tandem cylinder, one piston rod

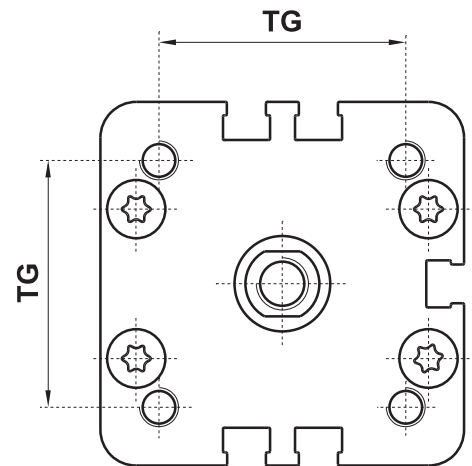
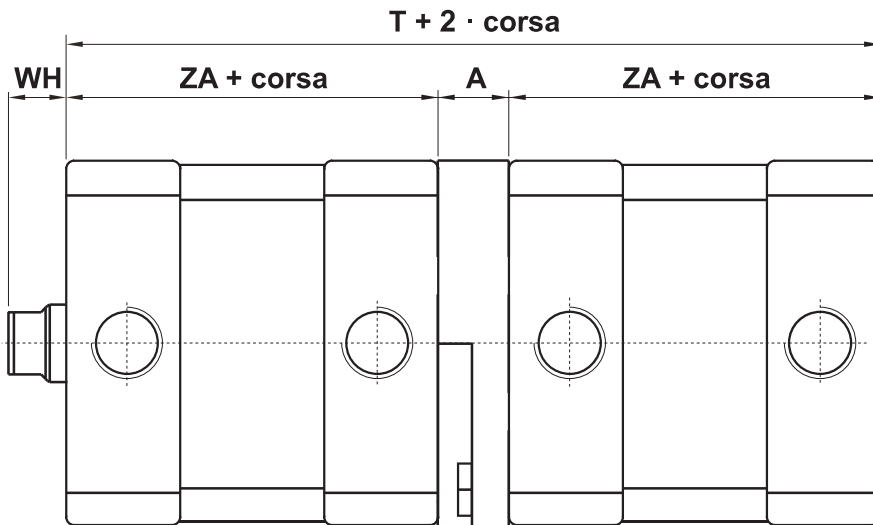

alesaggio bore	A	TG ±0.1		T	WH	ZA
		ISO	UNITOP			
25	10.5	26	-	88.5	6	39
32	10.5	32,5	32,5	98,5	7	44
40	12,5	38	42	102,5	7	45
50	12,5	46,5	50	102,5	8	45
63	13,5	56,5	62	111,5	8	49
80	15	72	82	123	10	54
100	15	89	103	149	10	67

Esempio di codifica

Example of order code

Q11F20320100

U11F20320100

## FLANGIA INTERMEDIA PER CILINDRI COMPATTI CONTRAPPOSTI

intermediate flange for opposite compact cylinders

Questa flangia intermedia deve essere inserita tra due cilindri compatti ISO 21287 per formare un cilindro contrapposto. È venduta in kit con tutti i particolari necessari al suo assemblaggio.

*This intermediate flange is inserted between two compact cylinders ISO 21287 to form an opposite cylinder. It is sold in kit with all necessary pieces for installation.*

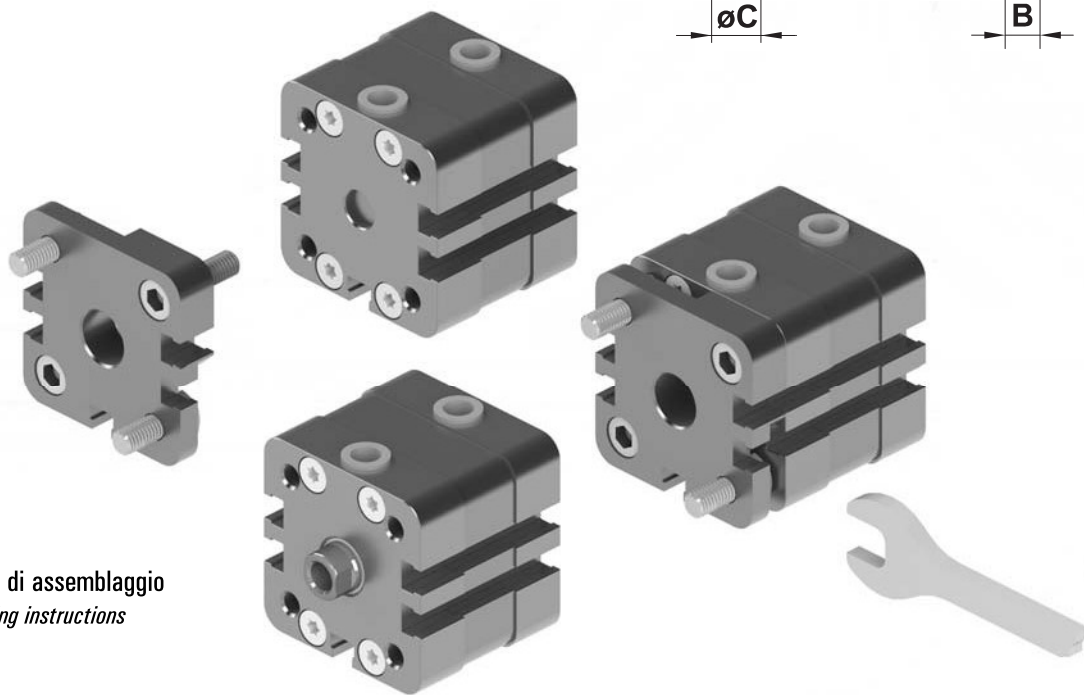
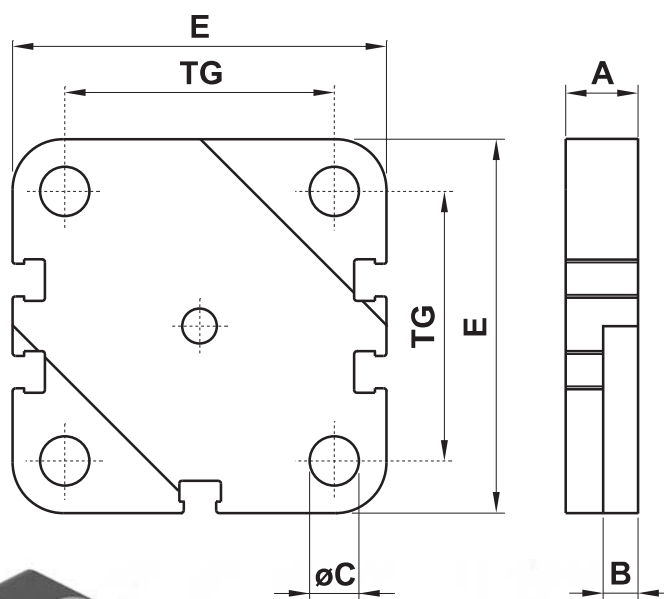

Schema di assemblaggio  
Assembling instructions

codice code		per alesaggio for bore	A	TG ±0.1		B	C	E
ISO	UNITOP			ISO	UNITOP			
39.081.2	-	25	10.5	26	-	5	5.5	42.7
39.082.2	39.082.2	32	10.5	32.5	32.5	5	6.5	49
39.083.2	39.088.2	40	12.5	38	42	6	6.5	56
39.084.2	39.089.2	50	12.5	46.5	50	6	8.5	69
39.085.2	39.090.2	63	13.5	56.5	62	7	8.5	79
39.086.2	39.091.2	80	15	72	82	7	10.5	95
39.087.2	39.092.2	100	15	89	103	7	10.5	115.5

## CILINDRO COMPATTO CONTRAPPOSTO

opposite compact cylinder

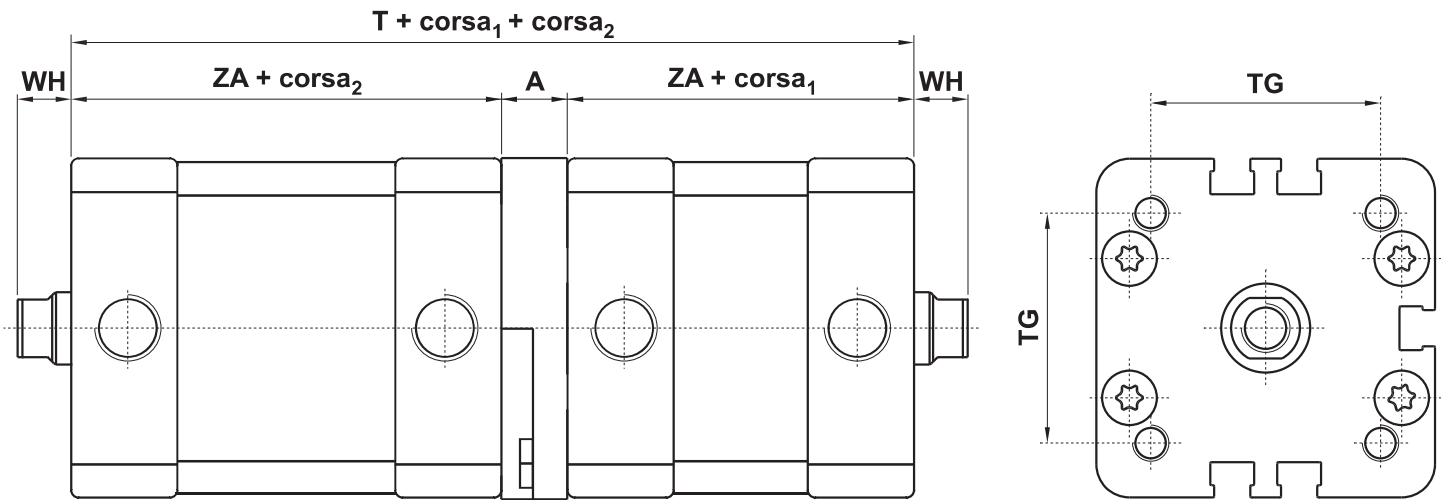

### Contrapposto a 3 posizioni

Opposite cylinder with 3 positions

Per questa configurazione le due parti del cilindro contrapposto devono avere la stessa corsa.

To achieve this configuration two cylinders of identical stroke length must be connected together.

### Contrapposto a 4 posizioni

Opposite cylinder with 4 positions

Per questa configurazione le due parti del cilindro contrapposto devono avere corse differenti.

To achieve this configuration two cylinders of different stroke length must be connected together.

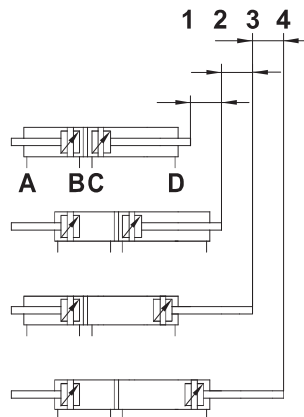
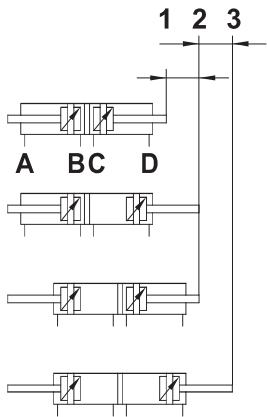

### Esempio di codifica

Example of order code

Q11D20320100/0150  
corsa<sub>1</sub> corsa<sub>2</sub>

U11D20320100/0150  
corsa<sub>1</sub> corsa<sub>2</sub>

alesaggio bore	A	TG ±0.1		T	WH	ZA
		ISO	UNITOP			
25	10.5	26	26	88.5	6	39
32	10.5	32.5	32.5	98.5	7	44
40	12.5	38	42	102.5	7	45
50	12.5	46.5	50	102.5	8	45
63	13.5	56.5	62	111.5	8	49
80	15	72	82	123	10	54
100	15	89	103	149	10	67

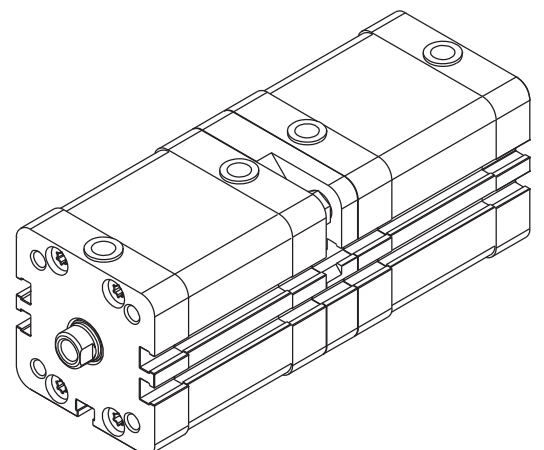

## KIT CILINDRO COMPATTO ISO 21287 E UNITOP

compact cylinder kit for ISO 21287 and UNITOP

### Il kit comprende:

- testate premontate
- pistone in alluminio con magnete, guarnizioni e anello di guida
- viti
- tutte le guarnizioni necessarie

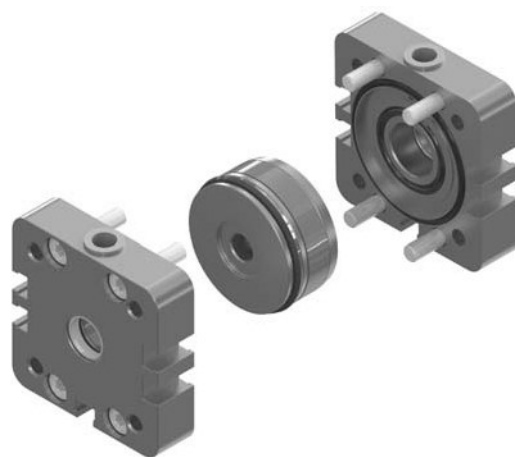

### MAGNETICO, guarnizioni standard

normale					stelo passante <i>[passing-through rod]</i>				
per alesaggio <i>for bore</i>	ISO		UNITOP		per alesaggio <i>for bore</i>	ISO		UNITOP	
	sigla <i>part number</i>	codice <i>code</i>	sigla <i>part number</i>	codice <i>code</i>		sigla <i>part number</i>	codice <i>code</i>	sigla <i>part number</i>	codice <i>code</i>
25	<b>KQ025</b>	39.003.3			25	<b>KQ025P</b>	39.013.3		
32	<b>KQ032</b>	39.004.3	<b>KQ032</b>	39.004.3	32	<b>KQ032P</b>	39.014.3	<b>KQ032P</b>	39.014.3
40	<b>KQ040</b>	39.005.3	<b>KU040</b>	39.105.3	40	<b>KQ040P</b>	39.015.3	<b>KU040P</b>	39.115.3
50	<b>KQ050</b>	39.006.3	<b>KU050</b>	39.106.3	50	<b>KQ050P</b>	39.016.3	<b>KU050P</b>	39.116.3
63	<b>KQ063</b>	39.007.3	<b>KU063</b>	39.107.3	63	<b>KQ063P</b>	39.017.3	<b>KU063P</b>	39.117.3
80	<b>KQ080</b>	39.008.3	<b>KU080</b>	39.108.3	80	<b>KQ080P</b>	39.018.3	<b>KU080P</b>	39.118.3
100	<b>KQ100</b>	39.009.3	<b>KU100</b>	39.109.3	100	<b>KQ100P</b>	39.019.3	<b>KU100P</b>	39.119.3

### MAGNETICO, guarnizioni VITON

normale					stelo passante <i>[passing-through rod]</i>				
per alesaggio <i>for bore</i>	ISO		UNITOP		per alesaggio <i>for bore</i>	ISO		UNITOP	
	sigla <i>part number</i>	codice <i>code</i>	sigla <i>part number</i>	codice <i>code</i>		sigla <i>part number</i>	codice <i>code</i>	sigla <i>part number</i>	codice <i>code</i>
25	<b>KQ025V</b>	39.023.3			25	<b>KQ025PV</b>	39.033.3		
32	<b>KQ032V</b>	39.024.3	<b>KQ032V</b>	39.024.3	32	<b>KQ032PV</b>	39.034.3	<b>KQ032PV</b>	39.034.3
40	<b>KQ040V</b>	39.025.3	<b>KU040V</b>	39.125.3	40	<b>KQ040PV</b>	39.035.3	<b>KU040PV</b>	39.135.3
50	<b>KQ050V</b>	39.026.3	<b>KU050V</b>	39.126.3	50	<b>KQ050PV</b>	39.036.3	<b>KU050PV</b>	39.136.3
63	<b>KQ063V</b>	39.027.3	<b>KU063V</b>	39.127.3	63	<b>KQ063PV</b>	39.037.3	<b>KU063PV</b>	39.137.3
80	<b>KQ080V</b>	39.028.3	<b>KU080V</b>	39.128.3	80	<b>KQ080PV</b>	39.038.3	<b>KU080PV</b>	39.138.3
100	<b>KQ100V</b>	39.029.3	<b>KU100V</b>	39.129.3	100	<b>KQ100PV</b>	39.039.3	<b>KU100PV</b>	39.139.3

Maggiori informazioni sono disponibili all'indirizzo internet <http://www.azpneumatica.srl/azweb/ita/kitcilq.htm>

More information is available at the internet address <http://www.azpneumatica.srl/azweb/ita/kitcilq.htm>

# barre per camicia cilindri compatti

barrel for compact cylinders



	codice di ordinazione order code	dimensioni - dimensions [mm]					peso weight [kg/m]
		A	B	C	D	E	
	<b>000.552.7</b>	$\varnothing 25^{H11}$	26	39.7	26	-	2.045
	<b>000.553.7</b>	$\varnothing 32^{\pm 0.1}$	18.5	48.2	39	11.05	2.075
	<b>000.554.7</b>	$\varnothing 40^{\pm 0.1}$	23	55	45	11.05	2.52
	<b>000.555.7</b>	$\varnothing 50^{\pm 0.1}$	29	68	55	10	3.384
	<b>000.556.7</b>	$\varnothing 63^{\pm 0.125}$	38	79	65	19	4.155
	<b>000.557.7</b>	$\varnothing 80^{\pm 0.125}$	48	94	80	27	5.371
	<b>000.558.7</b>	$\varnothing 100^{+0.2}_{-0.1}$	62	114.5	99	40	7.641

composizione chimica chemical composition	Cu	Fe	Mn	Mg	Si	Zn	Cr	Ti	Al resto
	$\leq 0.10$	$0.10 \div 0.30$	$\leq 0.10$	$0.35 \div 0.60$	$0.30 \div 0.60$	$\leq 0.15$	$\leq 0.05$	$\leq 0.10$	

## Fori di fissaggio

dal  $\varnothing 25$  al  $\varnothing 100$  : predisposti per l'uso di viti autofilettanti

## Fixing holes

from  $\varnothing 25$  to  $\varnothing 100$  : prepared for the use of self-tapping screws

# fissaggi per cilindri compatti ISO 21287

fixing elements for ISO 21287 compact cylinders



Per altre informazioni vedi le pagine 538-544 (fissaggi per cilindri ISO 15552)

For more information refer to pages 538-544 (fixing elements for cylinders ISO 15552)

## CERNIERA MASCHIO SNODO SFERICO (ø32 ... ø100)

CMSS...

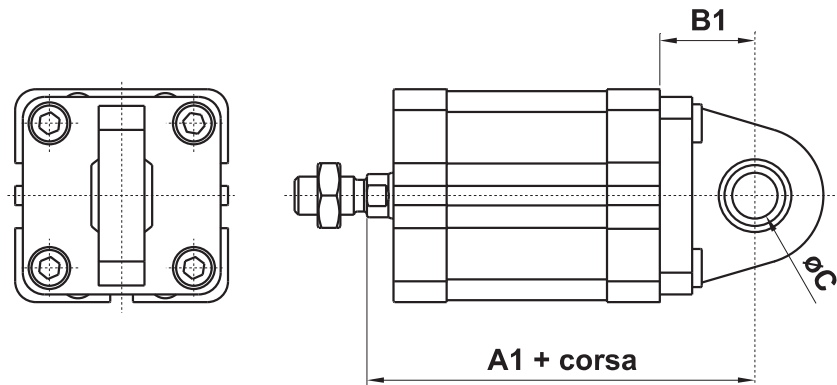

## CERNIERA MASCHIO (ø25 ... ø100)

CMIS...  
CMKS...

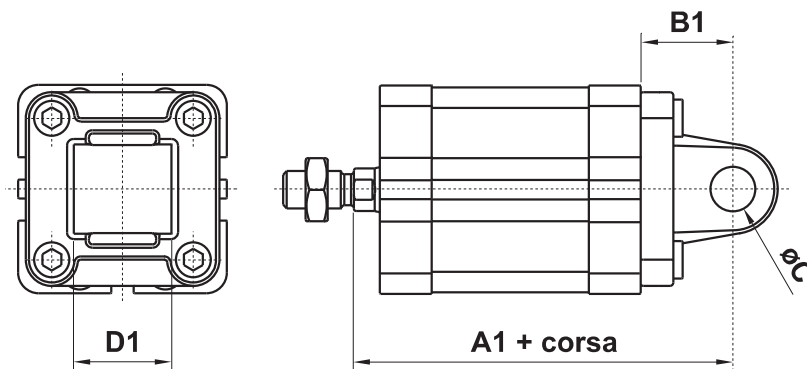

## CERNIERA FEMMINA CON PERNO (ø32 ... ø100)

CFIS...  
CFKS...

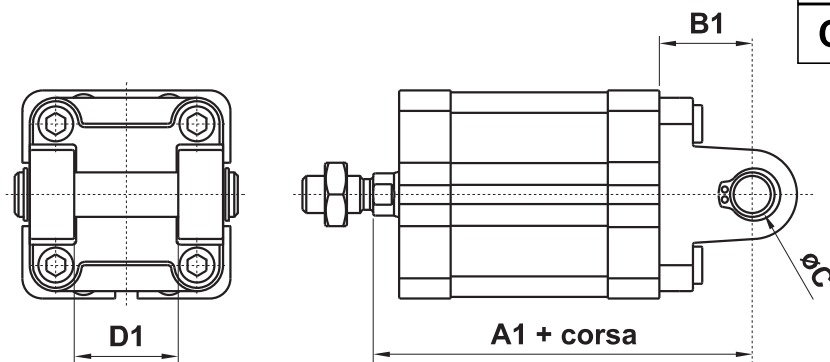

ø	A1	B1	C	D1
25	65	20	8	16
32	73	22	10	26
40	77	25	12	28
50	80	27	12	32
63	89	32	16	40
80	100	36	16	50
100	118	41	20	60

# fissaggi per cilindri compatti ISO 21287

fixing elements for ISO 21287 compact cylinders



Per altre informazioni vedi le pagine 538-544 (fissaggi per cilindri ISO 15552)

For more information refer to pages 538-544 (fixing elements for cylinders ISO 15552)

## FLANGIA

FLIS...

disegno per alesaggio 32-100

drawing for bore 32-100

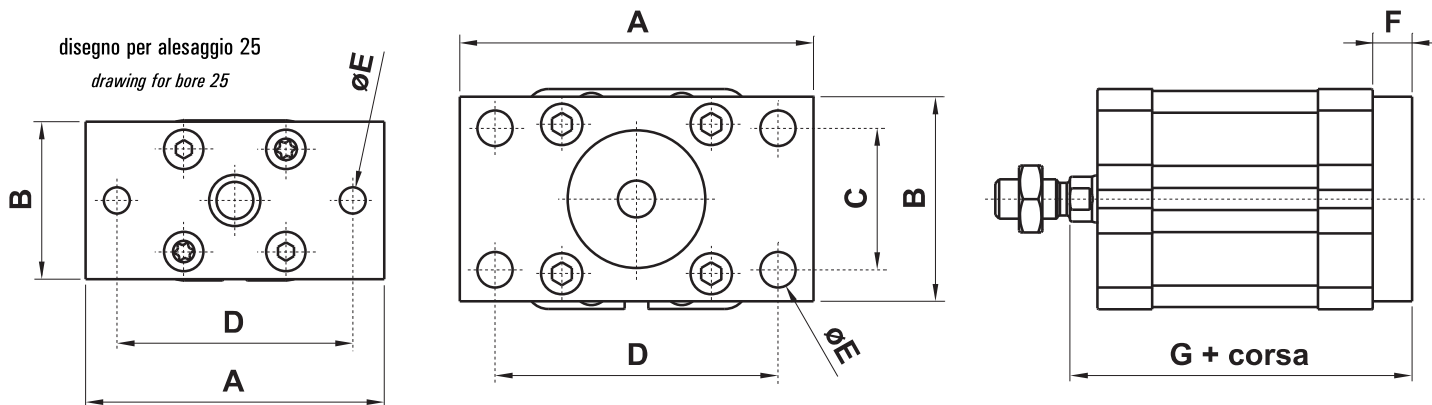

## PIEDINO

PBIS...

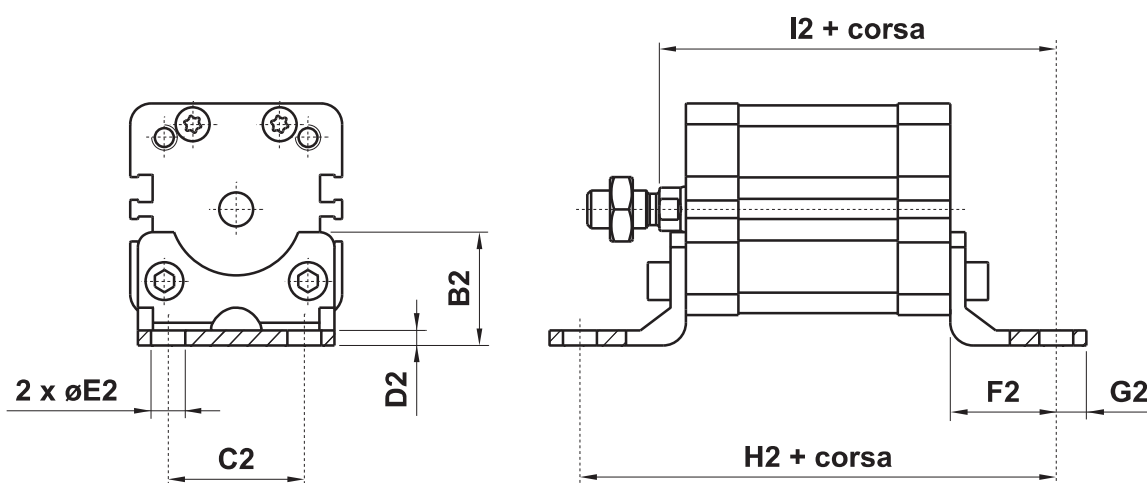

G	F	E	D	C	B	A	ø	B2	C2	D2	E2	F2	G2	H2	I2
55	10	6.6	60	-	40	76	25	23	26	4	6.6	17	6	73	62
61	10	7	64	32	45	80	32	30	32	4	7	24	11	92	75
62	10	9	72	36	52	90	40	30	36	4	9	28	8	101	80
65	12	9	90	45	65	110	50	36	45	5	9	32	15	109	85
69	12	9	100	50	75	120	63	35	50	5	9	32	13	113	89
80	16	12	126	63	95	150	80	47	63	5	12	41	14	136	105
93	16	14	150	75	115	170	100	53	75	8	14	41	16	149	118



## SCHEMA PER LA SCELTA DEGLI ACCESSORI ISO 21287

scheme for the choice of accessories ISO 21287

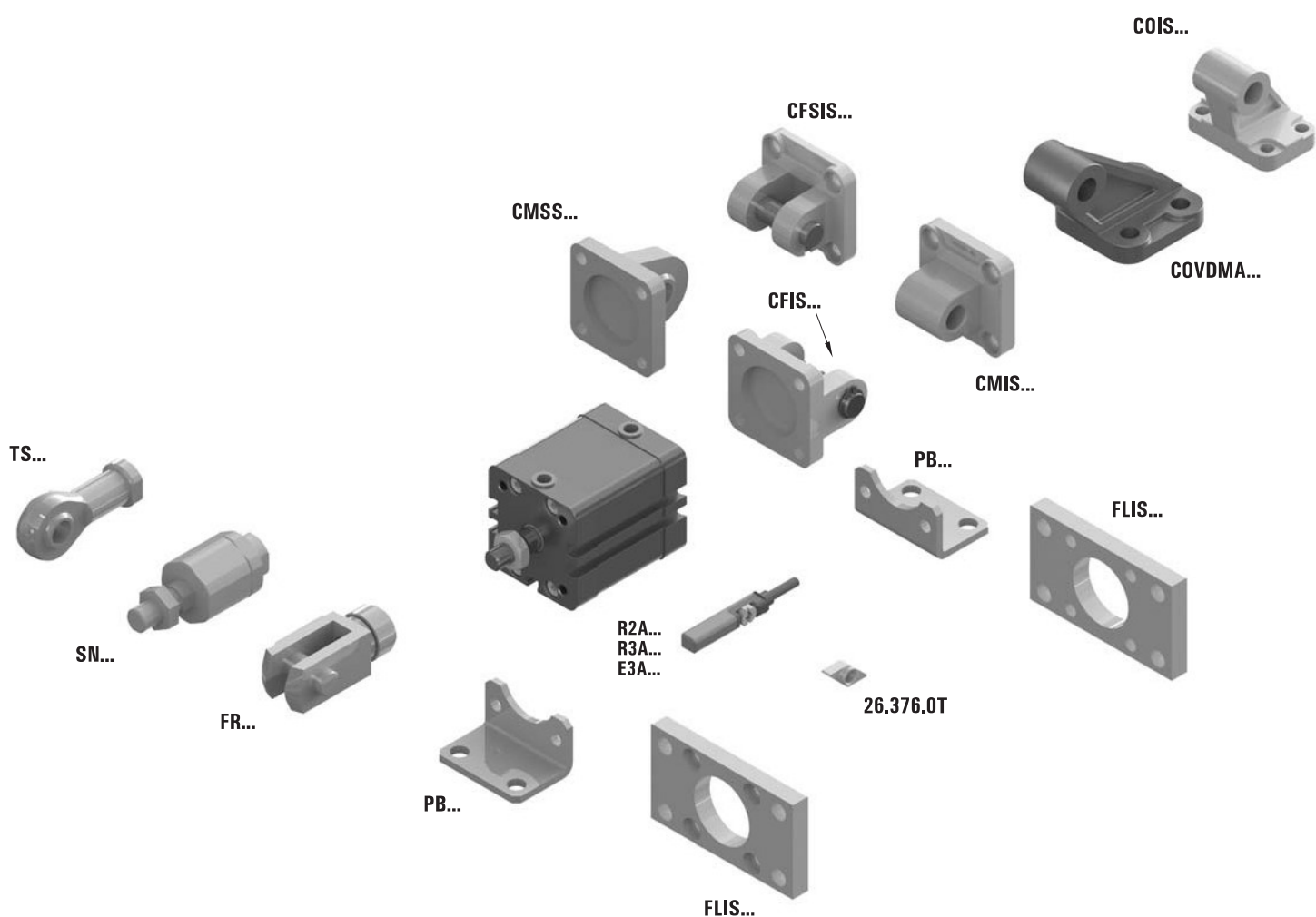

6



## CERNIERA FEMMINA CON PERNO (female hinge with pin)

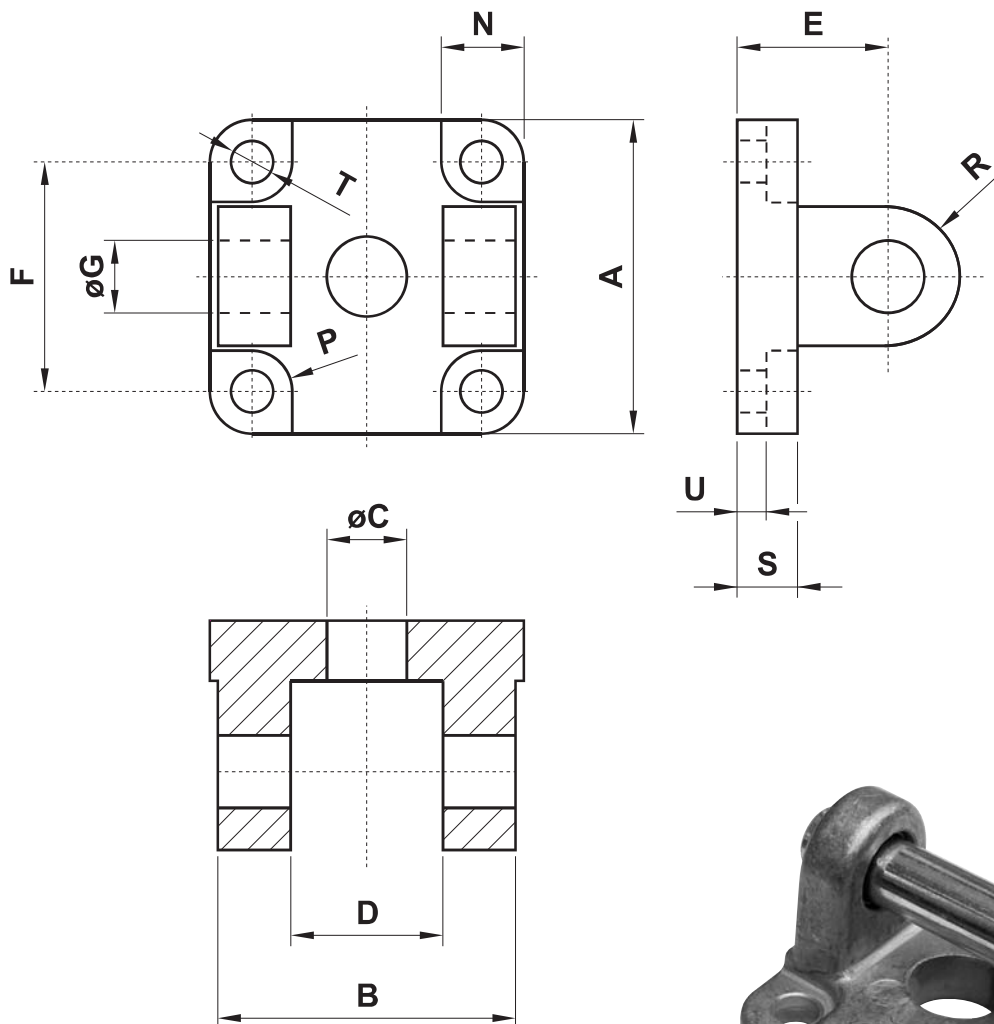

6

sigla part number	sigla part number	per alesaggio for bore	A	B	C	D	E	F	G	N	P	R	S	T	U
standard	con boccia di bronzo														
<b>CFUN032</b>	<b>CFKN032</b>	32	48	45	14	26	22	32	10	13.5	5.5	10	9	6.6	5.5
<b>CFUN040</b>	<b>CFKN040</b>	40	58	52	14	28	25	42	12	13.5	5.5	12.5	9	6.6	5.5
<b>CFUN050</b>	<b>CFKN050</b>	50	66	60	18	32	27	50	12	15.5	7.5	12.5	11	9	6.5
<b>CFUN063</b>	<b>CFKN063</b>	63	83	70	18	40	32	62	16	18	7.5	15	11	11	6.5
<b>CFUN080</b>	<b>CFKN080</b>	80	102	90	23	50	36	82	16	19	9	15	13	11	10
<b>CFUN100</b>	<b>CFKN100</b>	100	123	110	28	60	41	103	20	19	9	20	15	11	10

## FLANGIA (flange)

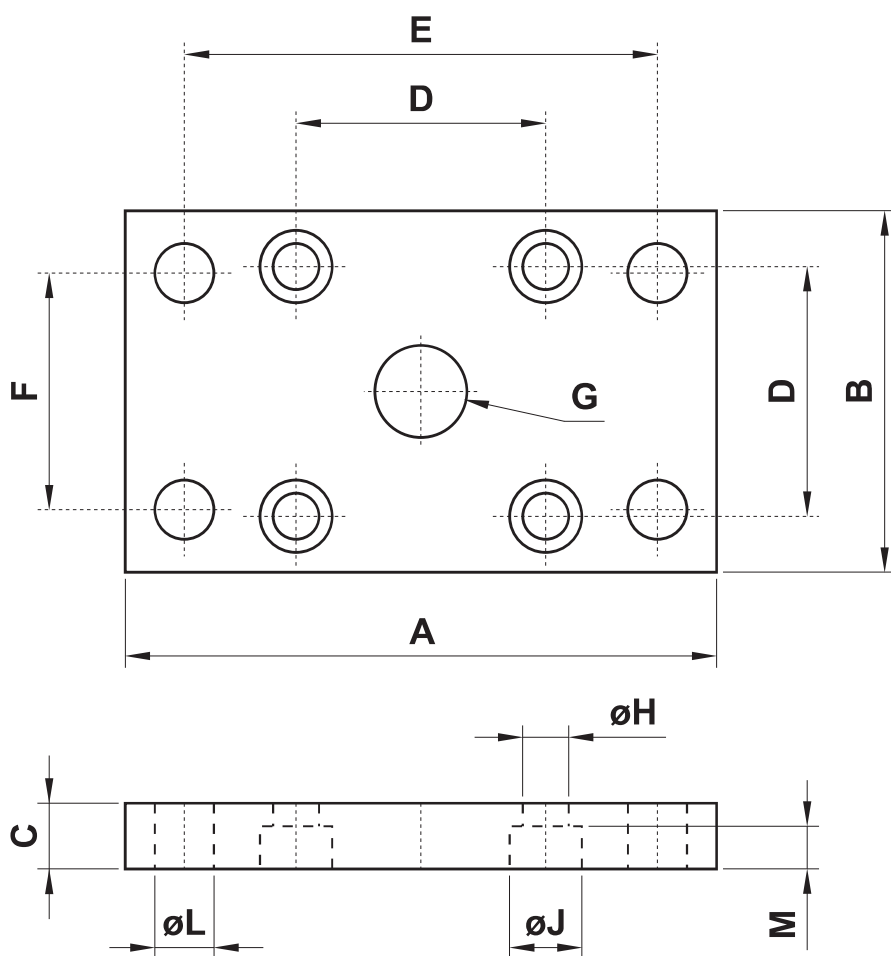
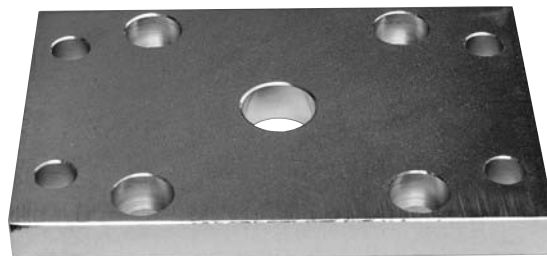

sigla part number	per alesaggio for bore	A	B	C	D	E	F	G	H	J	L	M
<b>FLUN032</b>	32	80	50	10	32	65	32	ø14	6.6	11	7	6.4
<b>FLUN040</b>	40	102	60	10	42	82	36	ø14	6.6	11	9	6.4
<b>FLUN050</b>	50	110	68	12	50	90	45	ø18	9	15	9	8.6
<b>FLUN063</b>	63	130	87	15	62	110	50	ø18	11	15	9	8.6
<b>FLUN080</b>	80	160	107	15	82	135	63	ø23	11	18	12	10.6
<b>FLUN100</b>	100	190	128	15	103	163	75	ø28	11	18	14	10.6

## PIEDINO (foot mounting)

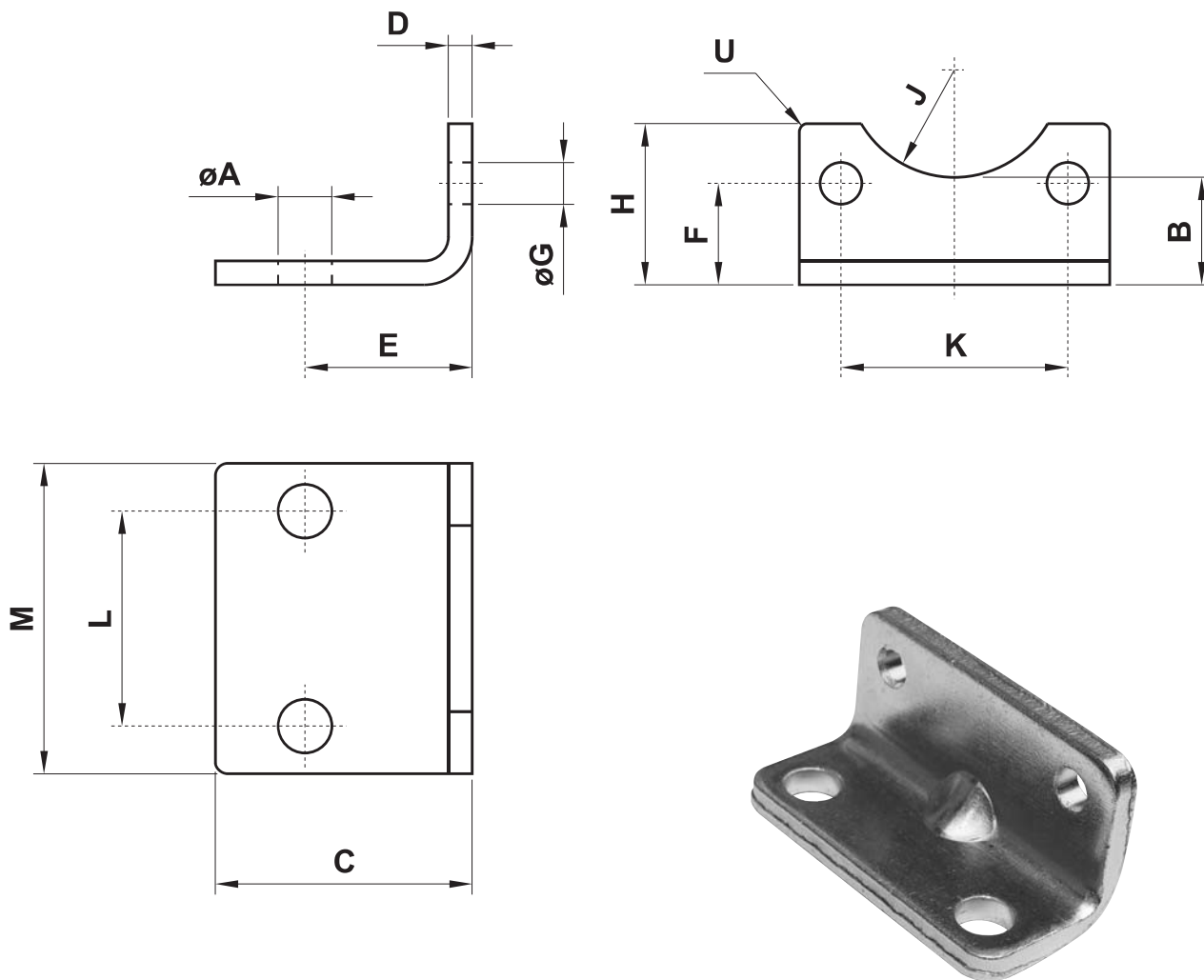

sigla* part number*	per alesaggio for bore	A	B	C	D	E	F	G	H	J	K	L	M	U
<b>PBUN025</b>	25	6.6	19	22	4	16	17	5.4	23	11	26	26	40	2
<b>PBUN032</b>	32	6.6	20	26	5	18	16	6.6	24	12	32	32	50	2
<b>PBUN040</b>	40	9	-	28	5	20	21.5	6.6	29.5	-	42	42	60	5
<b>PBUN050</b>	50	9	-	32	6	24	22	9	30	-	50	50	68	5
<b>PBUN063</b>	63	11	-	39	6	27	28.5	9	39	-	62	62	84	5
<b>PBUN080</b>	80	11	-	42	8	30	24.5	11	36.5	-	82	82	102	5
<b>PBUN100</b>	100	13.5	-	45	8	33	26.5	11	38.5	-	103	103	123	5

\* La sigla si riferisce a un solo piedino e non alla coppia

\* The part number is referred to only one element and not to the couple